

# StrapPack<sup>®</sup>

## NEW Semi-Automatic Strapping Machine



i-10

Distributed By:  
**Allstrap**  
1719 Kenny Rd  
Columbus, OH, 43212

# i-10



## NEW Semi-Automatic Strapping Machine

- The I-10 runs strap from 5 millimeters to 15.5 millimeters (5/8 inches) without additional parts.
- Seal time extension (maximum one-half second) is equipped for use of heavy strap.
- The machine is ready to operate in only 45 seconds.
- The I-10 has hardly any moving parts, which makes it easy to maintain and keeps the operation cost low.
- Stabilized tensioning, controlled electronically with a microprocessor, can easily be adjusted from 2 kilogram-force (4.4 pounds) to 40 kilogram-force (88 pounds) with a single dial.

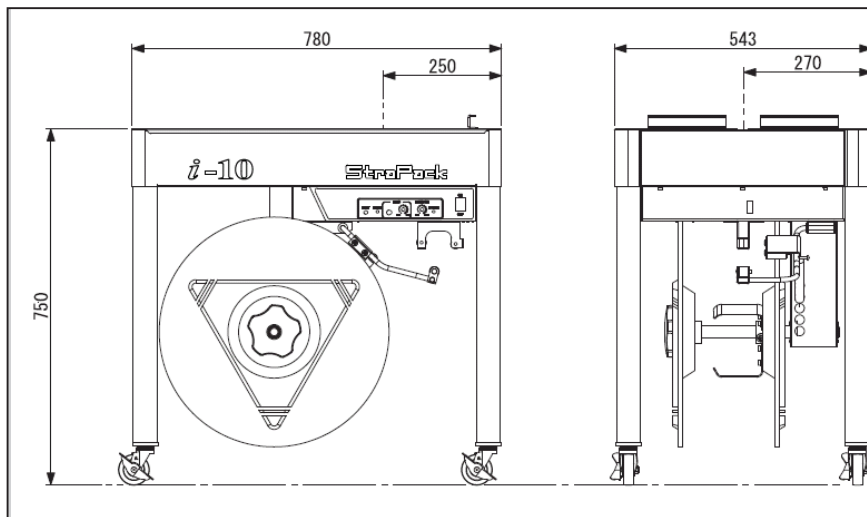

### ■ Standard Specifications

<b>Dimension</b>	<b>Width</b>	780 mm	30-3/4 in.
	<b>Height</b>	775 mm(with work guide)	30-1/2 in.(with work guide)
	<b>Depth</b>	543 mm	21-3/8 in.
	<b>Weight</b>	45 kg.	100 lbs.
<b>Table Height</b>		750 mm	29-1/2 in.
<b>Min. Package Size</b>		W 100 X H 30 mm	W 3-7/8 X H 1-1/8 in.
<b>Joint / Strap/ Coil</b>		heat seal / polypropylene ID 200 or 230 X W 200 mm	heat seal / polypropylene 8 X 8 or 9 X 8 in.
<b>Strap Width</b>		5, 6,9,12 (15.5) mm /0.45-0.7mm	1/4,3/8,1/2 (5/8) in./ 0.017-0.027 in.
<b>Strap Tension</b>		Max. 392 N (40 kgf)	Max. 88 lbsf.
<b>Power Supply</b>		100-120, 200-240 V	1 Phase 50 / 60 Hz 0.25 KVA

Dimensions and specifications are subject to change without notice.

Modification rights reserved.

Pats., U.M. & design registered and/or pending.

© 2010 Strapack Corporation

Distributed By:  
**Allstrap**  
 1719 Kenny Rd  
 Columbus, OH, 43212