

# FROMM

OPERATION MANUAL / SPARE PARTS LIST

## BATTERY - POWERED PLASTIC STRAPPING TOOL MODEL P325

43.0733.01

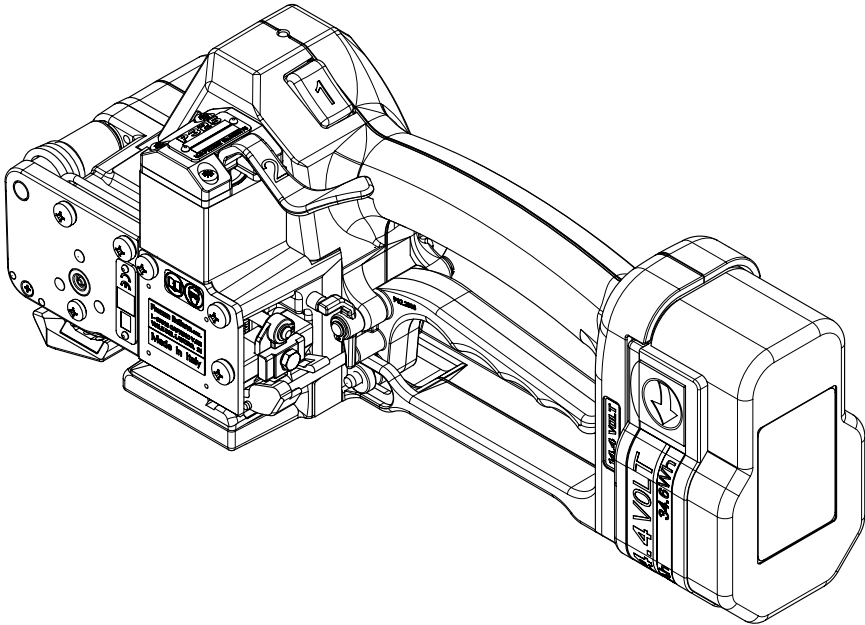

### CE Declaration of conformity

We declare that the machine P325  
is in conformity with the following standard or  
standardised documents:  
98/37/EEC

FROMM Holding AG  
Hinterbergstrasse 26  
CH - 6330 Cham  
16.02.2006

  
R.Fromm  
Director



Distributed By:  
**Allstrap**  
1719 Kenny Rd  
Columbus, OH, 43212

	<b>INDEX</b>	<b>PAGE</b>
<b>1</b>	<b>GENERAL SAFETY RULES</b>	<b>3</b>
<b>2</b>	<b>SAFETY RULES FOR STRAPPING TOOLS</b>	<b>5</b>
<b>3</b>	<b>TECHNICAL DATA</b>	<b>6</b>
<b>4</b>	<b>ACCESSORIES</b>	<b>7</b>
4.1	Battery . . . . .	7
4.2	Battery - chargers . . . . .	7
4.3	Wearing plate . . . . .	8
4.4	Suspension . . . . .	8
4.5	Turning button kit. . . . .	9
<b>5</b>	<b>OPERATING ELEMENTS</b>	<b>10</b>
<b>6</b>	<b>OPERATION</b>	<b>10</b>
6.1	Installation . . . . .	10
6.2	Adjustments. . . . .	11
6.3	Feeding the strap around the package . . . . .	12
6.4	Inserting the strap . . . . .	12
6.5	Tensioning the strap . . . . .	12
6.6	Sealing of the joint. . . . .	13
6.7	Removing the tool . . . . .	13
6.8	Seal - Control. . . . .	13
<b>7</b>	<b>CHART OF TYPES</b>	<b>14</b>
<b>8</b>	<b>ELECTRIC SCHEMATIC</b>	<b>14</b>
<b>9</b>	<b>EXCHANGE OF WEARING PARTS</b>	<b>15</b>
9.1	Exchange of tensioning wheel and grippers . . . . .	15
9.2	Exchange of cutter, welding stop gripper and welding gripper . . . . .	16
9.3	Adjustment of the coupler . . . . .	17
<b>10</b>	<b>SERVICE</b>	<b>17</b>
<b>11</b>	<b>CLEANING</b>	<b>17</b>
<b>12</b>	<b>WARRANTY CONDITIONS AND LIABILITY</b>	<b>18</b>
<b>13</b>	<b>APPROPRIATE USE</b>	<b>18</b>
<b>14</b>	<b>SPARE PARTS LIST 43.0733.01</b>	<b>23</b>

Distributed By:

**Allstrap**1719 Kenny Rd  
Columbus, OH, 43212

## **1 GENERAL SAFETY RULES**

**WARNING! Read all instructions.** Failure to follow all instructions listed below may result in electric shock, fire and/ or serious injury. The term "power tool" in all of the warnings listed below refers to your mains operated (corded) power tool or battery operated (cordless) power tool.

SAVE THESE INSTRUCTIONS.

### **1.1 Work area**

- a) **Keep work area clean and well lit.** Cluttered and dark areas invite accidents.
- b) **Do not operate power tools in explosive atmospheres, such as in the presence of flammable liquids, gases or dust.** Power tools create sparks which may ignite the dust or fumes.
- c) **Keep children and bystanders away while operating a power tool.** Distractions can cause you to lose control.

### **1.2 Electrical safety**

- a) **Power tool plugs must match the outlet. Never modify the plug in any way. Do not use any adapter plugs with earthed (grounded) power tools.** Unmodified plugs and matching outlets will reduce the risk of electric shock.
- b) **Avoid body contact with earthed or grounded surfaces such as pipes, radiators, ranges and refrigerators.** There is an increased risk of electric shock if your body is earthed or grounded.
- c) **Do not expose power tools to rain or wet conditions.** Water entering a power tool will increase the risk of electric shock.
- d) **Do not abuse the cord. Never use the cord for carrying, pulling or unplugging the power tool. Keep cord away from heat, oil, sharp edges or moving parts.** Damaged or entangled cords increase the risk of electric shock.
- e) **When operating a power tool outdoors, use an extension cord suitable for outdoor use.** Use of a cord suitable for outdoor use reduces the risk of electric shock.

### **1.3 Personal safety**

- a) **Stay alert, watch what you are doing and use common sense when operating a power tool. Do not use a power tool while you are tired or under the influence of drugs, alcohol or medication.** A moment of inattention while operating power tools may result in serious personal injury.
- b) **Use safety equipment. Always wear eye protection.** Safety equipment such as dust mask, non-skid safety shoes, hard hat, or hearing protection used for appropriate conditions will reduce personal injuries.
- c) **Avoid accidental starting. Ensure the switch is in the off position before plugging in.** Carrying power tools with your finger on the switch or plugging in power tools that have the switch on invites accidents.
- d) **Remove any adjusting key or wrench before turning the power tool on.** A wrench or a key left attached to a rotating part of the power tool may result in personal injury.
- e) **Do not overreach. Keep proper footing and balance at all times.** This enables better control of the power tool in unexpected situations.
- f) **Dress properly. Do not wear loose clothing or jewellery. Keep your hair, clothing and gloves away from moving parts.** Loose clothes, jewellery or long hair can be caught in moving parts.
- g) **If devices are provided for the connection of dust extraction and collection facilities, ensure these are connected and properly used.** Use of these devices can reduce dust related hazards.

## 1.4 Power tool use and care

- a) **Do not force the power tool. Use the correct power tool for your application.** The correct power tool will do the job better and safer at the rate for which it was designed.
- b) **Do not use the power tool if the switch does not turn it on and off.** Any power tool that cannot be controlled with the switch is dangerous and must be repaired.
- c) **Disconnect the plug from the power source before making any adjustments, changing accessories, or storing power tools.** Such preventive safety measures reduce the risk of starting the power tool accidentally.
- d) **Store idle power tools out of the reach of children and do not allow persons unfamiliar with the power tool or these instructions to operate the power tool.** Power tools are dangerous in the hands of untrained users.
- e) **Maintain power tools. Check for misalignment or binding of moving parts, breakage of parts and any other condition that may affect the operation of the power tool. If damaged, have the power tool repaired before use.** Many accidents are caused by poorly maintained power tools.
- f) **Keep cutting tools sharp and clean.** Properly maintained cutting tools with sharp cutting edges are less likely to bind and are easier to control.
- g) **Use the power tool, accessories and tool bits etc., in accordance with these instructions and in the manner intended for the particular type of power tool, taking into account the working conditions and the work to be performed.** Use of the power tool for operations different from those intended could result in a hazardous situation.

## 1.5 Battery tool use and care

- a) **Ensure the switch is in the off position before inserting the battery pack.** Inserting the battery pack into power tools that have the switch on invites accidents.
- b) **Recharge only with the charger specified by the manufacturer.** A charger that is suitable for one type of battery pack may create a risk of fire when used with another battery pack.
- c) **Use power tools only with specifically designated battery packs.** Use of any other battery packs may create a risk of injury and fire.
- d) **When the battery pack is not in use, keep it away from other metal objects like paper clips, coins, keys, nails, screws, or other small metal objects that can make a connection from one terminal to another.** Shorting the battery terminals together may cause burns or a fire.
- e) **Under abusive conditions, liquid may be ejected from the battery; avoid contact. If contact accidentally occurs, flush with water. If liquid contacts eyes, additionally seek medical help.** Liquid ejected from the battery may cause irritation or burns.

## 1.6 Service

- a) **Have your power tool repaired only by qualified personnel using original spare parts.** This will ensure that the safety of the power tool is maintained.

Distributed By:

**Allstrap**

1719 Kenny Rd  
Columbus, OH, 43212

## **2 SAFETY RULES FOR STRAPPING TOOLS**

### **2.1 Joints**

**You are fully responsible to review the joints made by your tool. Become familiar with the seal control and seal adjustment described in this operation manual.**

Misformed joints may not secure the load and could cause serious injury. Never handle or ship any load with improperly formed joints.

### **2.2 Dispensing strap**

**Only dispense strap from a dispenser specifically designed for strap.  
Tuck strap end back into dispenser when not in use.**

### **2.3 Strap warnings**

**Never use strap as a means of pulling or lifting loads.** Failure to follow these warnings can result in severe personal injury.

### **2.4 Strap breakage hazard**

Improper operation of the tool, excessive tensioning, using strap not recommended for this tool or sharp corners on the load can result in a sudden loss of strap tension or in strap breakage during tensioning, which could result in the following:

A sudden loss of balance causing you to fall.

Both tool and strap flying violently towards your face.

Note as follows:

**If the load corners are sharp, use edge protectors.**

**Place the strap correctly around a properly positioned load.**

**Positioning yourself in-line with the strap, during tensioning and sealing, can result in severe personal injury from flying strap or tool. When tensioning or sealing, position yourself to one side of the strap and keep all bystanders away.**

**Use the correct strap quality, strap width, strap gauge and strap tensile strength recommended in this manual for your tool.** Using strap not recommended for this tool can result in strap breakage during tensioning.

### **2.5 Cutting tensioned strap**

**When cutting strapping, use the proper strapping cutter** and keep other personnel and yourself at a safe distance from the strap. Always stand to side of the strap, away from the direction the loosened strap end will fly. Use only cutters designed for strap and never hammers, pliers, hacksaws, axes, etc.

### **2.6 Environment protection**

Do not dispose of used batteries in the household refuse, water or by burning them.

FROMM distributors offer an environment friendly battery disposal service.

Distributed By:

**Allstrap**

1719 Kenny Rd

Columbus, OH, 43212

### 3 TECHNICAL DATA

#### Description of the tool

The tool model P325 has been designed to strap packages with plastic strapping. The plastic strapping is fed around the package manually or in combination with a strap feeder. The straps are inserted in the tool, automatically tensioned, sealed by friction welding and separated.

#### Tool size with battery

Length:	355 mm / 14"
Width:	128 mm / 5"
Height:	128 mm / 5"
Weight:	4.4 kg / 9.7 lbs

#### Noise information

The A-weighted equivalent continuous sound level at the work place of the machine operator is typical 81 dB (A).

This value was determined according to DIN 45 635 T3 (11.85).

#### Vibration information

The weighted effective value of the acceleration typically amounts to less than 2,5m/s<sup>2</sup>.

This value was determined according to DIN EN 28 662 T1 (01.93).

#### Strap material

Strap qualities: PET (Polyester) and PP (Polypropylene) plain or embossed.  
**Use only plastic straps recommended by your sales shop (name and address on the rear of the operation manual).**

Strap dimensions: 16.0 - 19.0 mm x 0.4 - 1.35 mm (see chart of types).  
**Use only plastic straps with the correct strap dimensions for your tool.**

#### Strap tension

Tensioning force\*: Adjustable from 600 - max. 3500 N / 135 - max. 787 lbs.

Tensioning speed\*: approx. 100 - 130 mm/s / 3.9 - 5 inch/sec.

Joint strength\*: approx. 75% of the tensile strength of the plastic strap.

\* The value depends on the strap quality.

#### Working temperature

The ambient temperature should be between 5° and 45° C (41° and 113°F).

The best performance is achieved between 15° and 20°C (59° and 68°F).

Distributed By:

**Allstrap**

1719 Kenny Rd  
Columbus, OH, 43212

## 4 ACCESSORIES



Use only parts and accessories mentioned in the operating instruction. Using other parts or accessories can cause injuries to you and other persons.

### 4.1 Battery

Since the tool can be operated with NiCd or NiMH batteries, the battery is not automatically supplied with the tool. The battery has to be ordered separately under the following item numbers.

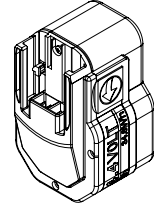

Item-No.	Battery	Voltage	Capacity
N5.4309	NiCd	14,4 VDC	2,4Ah
N5.4316	NiMH	14,4 VDC	3,0Ah

### 4.2 Battery - chargers

The charge must be ordered separately according to below shown table.

#### Standard charger

Item-No.	Voltage / frequency	Admitted for country
N5.4414	220 - 240V / 50 - 60Hz	A, B, BG, BIH, BOL, BR, BY, CH, CL, CZ, D, DK, DZ, E, EAS, EST, ET, F, FIN, GE, GR, H, HK, HR, I, IL, IND, IR, IRQ, IS, JOR, KSA, KWT, L, LAR, LT, LV, MA, MC, MK, MOC, N, NL, P, PK, PE, PL, PRC, PY, RA, RCH, RI, RL, RO, ROK, ROU, RP, RUS, S, SK, SLO, SYR, THA, TN, TR, UA, UAE, YU, YV, (Z), (ZA), (ZW)
N5.4416	220 - 240V / 50 - 60Hz	BRN, BRU, CY, EAK, EAT, GB, IRL, M, MAL, OM, SGP, Y
N5.4418	220 - 240V / 50 - 60Hz	AUS, NZ
N5.4420	220V / 60Hz	ROK

#### Turbo charger

Item-No.	Voltage / frequency	Admitted for country
N5.4422	220 - 240V / 50 - 60Hz	A, B, BG, BIH, BOL, BR, BY, CH, CL, CZ, D, DK, DZ, E, EAS, EST, ET, F, FIN, GE, GR, H, HK, HR, I, IL, IND, IR, IRQ, IS, JOR, KSA, KWT, L, LAR, LT, LV, MA, MC, MK, MOC, N, NL, P, PK, PE, PL, PRC, PY, RA, RCH, RI, RL, RO, ROK, ROU, RP, RUS, S, SK, SLO, SYR, THA, TN, TR, UA, UAE, YU, YV, (Z), (ZA), (ZW)
N5.4424	120V / 60Hz	BR, C, CDN, CO, CR, DOM, EC, GCA, J, JA, KSA, LB, MEX, NIC, PA, Puerto Rico, RC, RP, USA, YV
N5.4426	110V / 50 - 60Hz	GB
N5.4428	220 - 240V / 50 - 60Hz	BRN, BRU, CY, EAK, EAT, GB, IRL, M, MAL, OM, SGP, Y
N5.4430	220 - 240V / 50 - 60Hz	AUS, NZ

#### Charging times

Item-No.	Battery	Standard charger	Turbo charger
N5.4309	NiCd	approx. 80 min.	approx. 20 min.
N5.4316	NiMH	approx. 85 min.	approx. 25 min.

Distributed By:

**Allstrap**

1719 Kenny Rd  
Columbus, OH, 43212

**4.3 Wearing plate**

As an option, tool can be equipped with a wearing plate to protect base from excessive wear on abrasive package surfaces (like bricks, concrete blocks etc.). The complete wearing plate can be ordered together with the fastening screws under item number P32.0127.

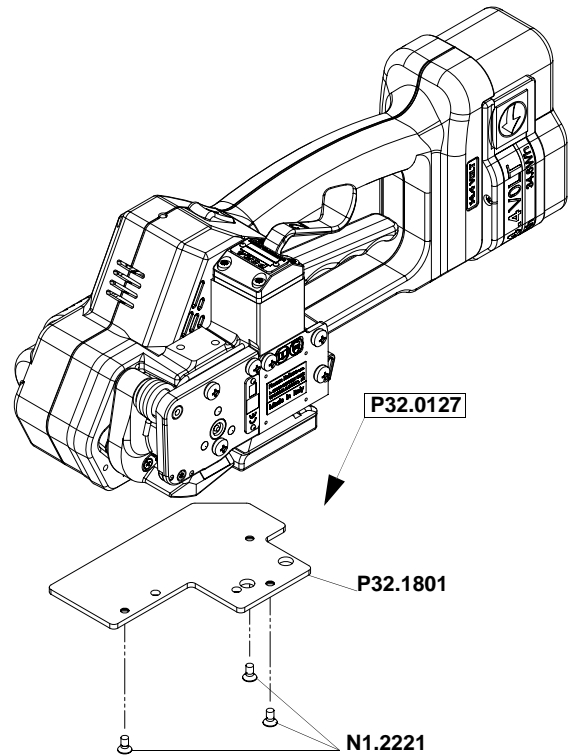

**4.4 Suspension**

When working stationary the P325 can be suspended at a spring loaded balancer by using a suspension bracket.

For working in normal position a stiff suspension bracket with screws and washers can be ordered under item number P32.0112.

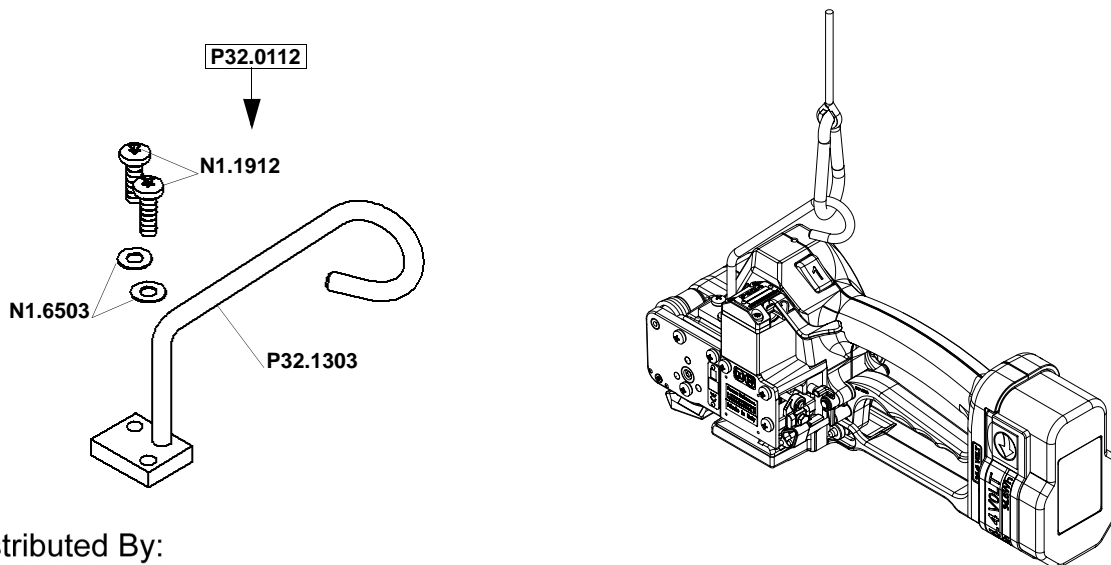

Distributed By:  
**Allstrap**

1719 Kenny Rd  
Columbus, OH, 43212



For working in alternating positions a turn able suspension bracket with screws and washers can be ordered under item number P32.0137.

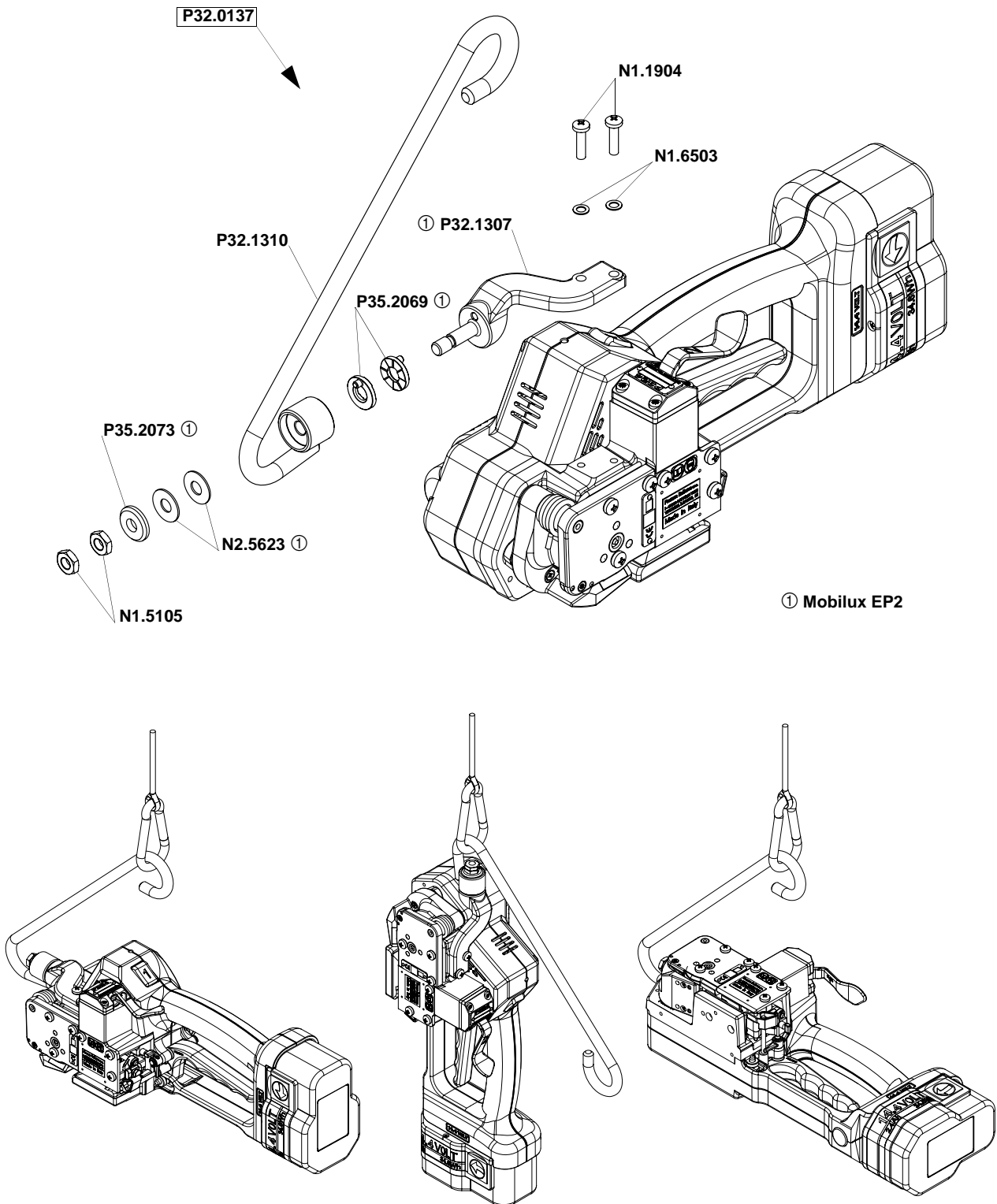

#### 4.5 Turning button kit

For a remaining adjustment of tension force and welding time.

After exchanging of the turning buttons the adjustment can only be changed with the allen key (2mm) that comes with the kit. The kit can be ordered under the item number P32.2061.

## 5 OPERATING ELEMENTS

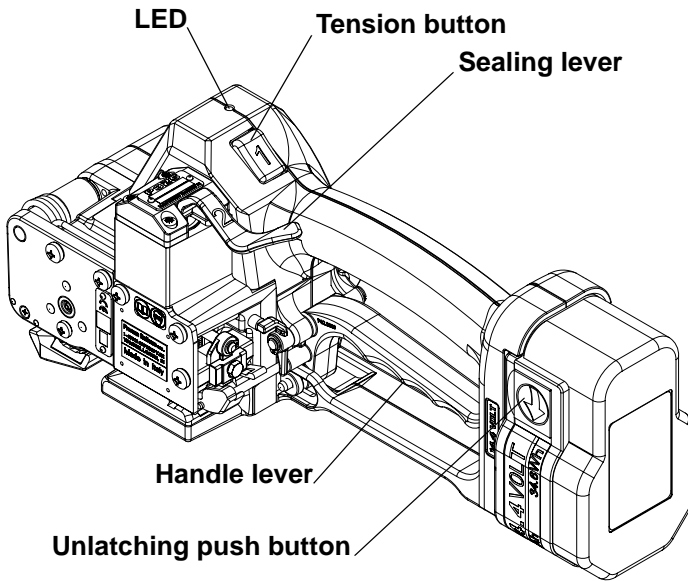

LED - Indication	
Green	During tensioning the LED lights green.
Green	During welding the LED lights green.
Yellow	Cooling time is running, the tool must not be removed from the strap.
Green	Cooling time is finished, the tool can be removed from the strap.
Red	Charge the battery.
Red blinking	The control board is overheated, the tool has to cool down, the switches are locked.

## 6 OPERATION

### 6.1 Installation

**Do not expose power tools to rain or wet conditions!**

For safety reasons the battery is delivered uncharged.

Charge the battery before working. See separate operating instruction of the battery charger.

**Never charge a damaged battery. Replace by a new one immediately.**

**Do not open batteries and store them only in dry and frost-proof rooms.**

**The maximum ambient temperature is 50°C.**

**Keep dry at all times.**

### Inserting the battery

Insert the battery from bottom to top into the tool **both unlatching push buttons latch.**

When inserting the battery the status of the charge is displayed shortly.

### Displaying of the status of the battery charge by LED

Green blinking	full
Green yellow blinking	3/4 full
Yellow blinking	1/2 full
Yellow - red blinking	1/4 full
Red blinking	empty

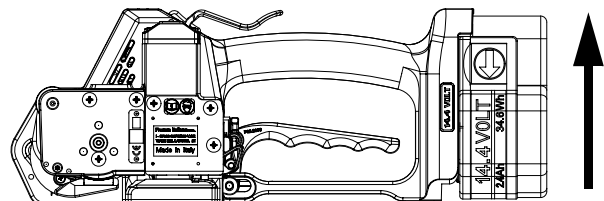

Distributed By:

**Allstrap**

1719 Kenny Rd  
Columbus, OH, 43212

## Removing the empty battery

If the red LED starts lighting while a tensioning or welding procedure, the capacity of the battery is exhausted. All electric functions of the tool are blocked.



**The seal efficiency is insufficient.**

**Warning! Straps with insufficient seal strength must be removed from the package!**

The battery must be recharged.

Push the unlatching push buttons at both sides of the battery.

Push the battery out of the tool in the opposite direction of insertion.

When removing the battery the LED lights shortly red.

## 6.2 Adjustments

### 6.2.1 Preselecting of strap tension and tensioning speed



**Do not adjust the tensioning force too high.**

**If the tensioning force is higher than the tensioning strength of the strap, the strap will tear while the tensioning.**

Tensioning force and tensioning speed can be preselected with the upper adjusting knob.

Turning clockwise increases;

turning counter clockwise decreases the tensioning force and the tensioning speed resp..

The tensioning force on the minimum setting is 600 N (135 lbs) and it is increased on the maximum setting to 3500 N (787 lbs).

The tensioning speed on the minimum setting is 100 mm/s (3.9 inch/sec), it is increased on the middle setting to 130 mm/s (5 inch/sec) and remains on this value till the maximum setting.

**Adjusting knob tensioning force / tensioning speed**

**Adjusting knob welding time**

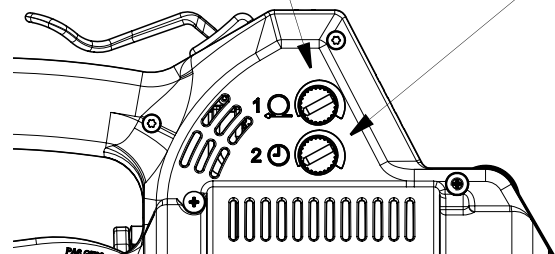

### 6.2.2 Adjusting the welding time

Depending on the size and quality of the strap, different welding times are required.

The welding time can be adjusted at the lower adjusting knob.

Turning clockwise increases,

turning counter clockwise decreases the welding time.

Distributed By:

**Allstrap**

1719 Kenny Rd

Columbus, OH, 43212

### 6.3 Feeding the strap around the package

The strapping is fed around the package as illustrated.

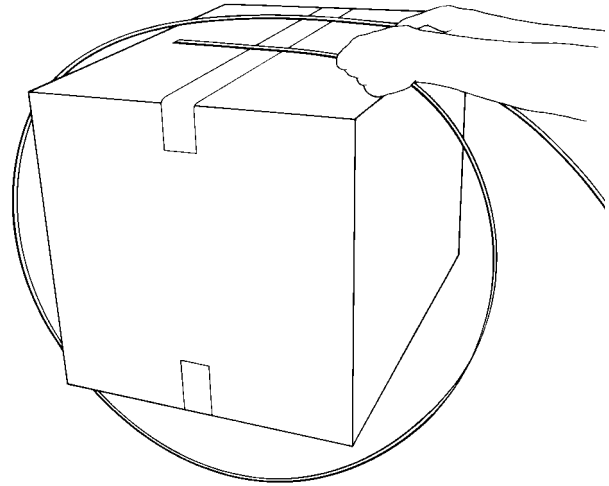

**Warning! The plastic strap which will be welded must be free from oil, grease and other dirt. Dirty plastic straps can't be welded correct!**

### 6.4 Inserting the strap

Pull up the handle lever firmly with your right hand.  
Insert the two straps well aligned on each other into the strap guide using your left hand.  
Release the handle lever.

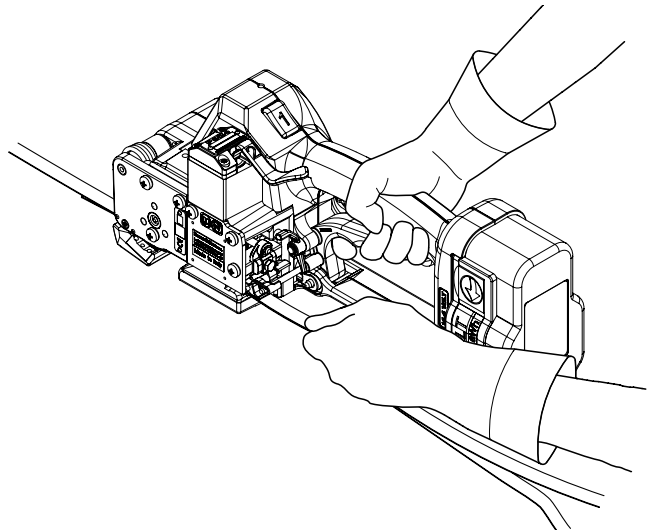

### 6.5 Tensioning the strap

Press down the tension button and then release it again after the desired strap tension has been reached.  
The tensioning operation can be interrupted and restarted at any time.  
During tensioning the LED lights green.

**Do not press the tension button after reaching the preselected tensioning.  
Danger of strap breakage.**

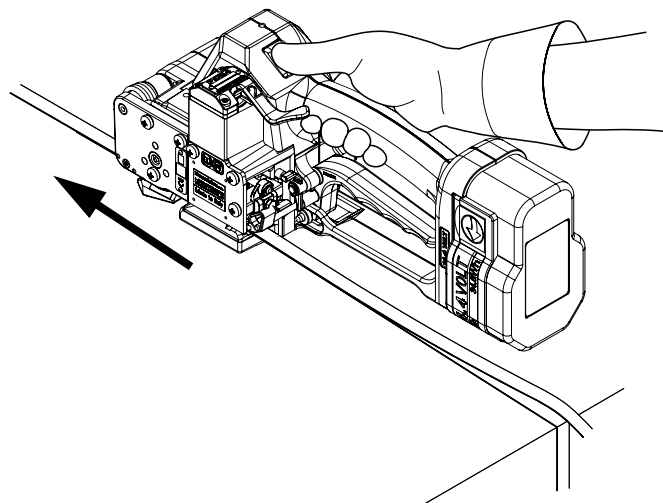

**The tool must carry out a balance movement while tensioning.**

**Therefore:**

- Don't hinder the tools movement in the signed direction.

**Disregard:**

- The feed wheel slips on the strap without tensioning it.

Distributed By:

**Allstrap**

1719 Kenny Rd  
Columbus, OH, 43212

## 6.6 Sealing of the joint

Press sealing lever down until it locks and let it go immediately.  
The plastic strap is welded and cut off from the rest of the strap.  
During the welding the LED lights green.

After elapsing of the adjusted welding time (see 6.2.2) the cooling time begins (LED lights yellow).  
During that time the tool must not be removed from the strap.  
If the LED lights green again, the sealing cycle is finished.

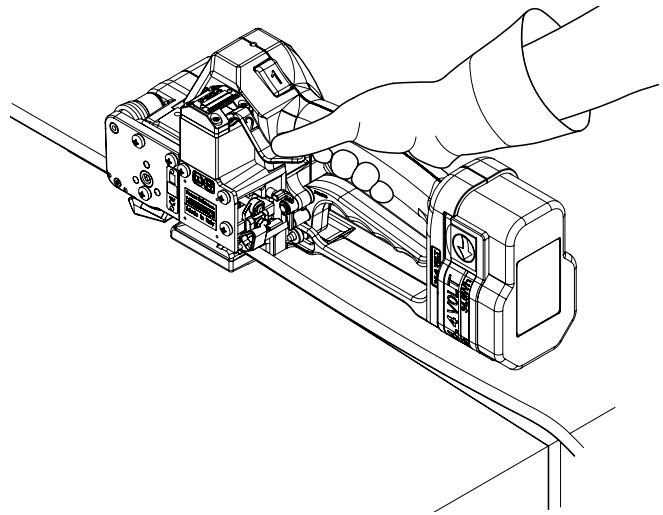

**The tool must not be removed from the strap as long as the cooling time is not finished. Disregard of this regulation is causing insufficient seal efficiencies, which can cause severe injuries.**

## 6.7 Removing the tool

Pull up the handle lever,  
pull the tool right / backwards and off the strapping.

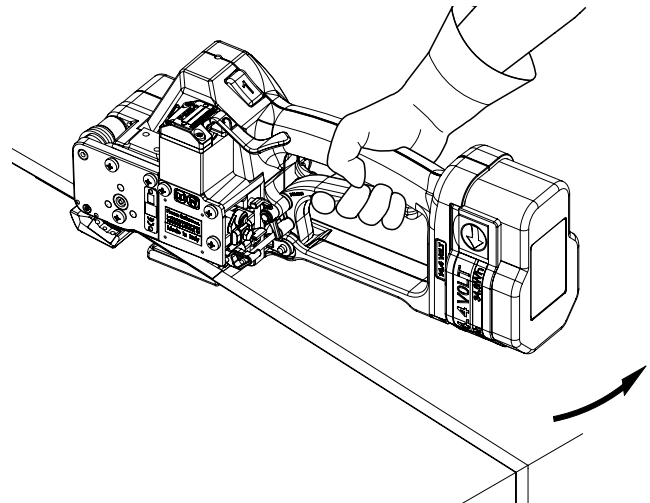

## 6.8 Seal - Control

A regular control of the seal is necessary. The seal can be examined visually.  
Make a seal, peel it apart and examine it as follows:



### Correct seal

The seal must be completely welded over the whole width of the strap on a length of ca. 19 mm. Minor quantities of fused plastic may overflow on sides.



### Welding time too short

The plastic strap is not welded over the whole width of the strap. The seal efficiency is insufficient.  
Warning! Straps with insufficient seal strength must be removed from the package! Adjust the welding time (see 6.2.2).



### Welding time too long

If the welding time is too long the straps are overheated. The fused plastic overflows on both sides of the straps. The seal efficiency is affected.  
Warning! Straps with insufficient seal strength must be removed from the package! Adjust the welding time (see 6.2.2).

## 7 CHART OF TYPES

Item No.	Model	Strap width	Strap thickness
43.0721	P325/16/0.65-1.05	16 mm / 5/8"	0.65-1.05 mm / .026 - .041"
43.0722	P325/16/1.06-1.35	16 mm / 5/8"	1.06-1.35 mm / .042 - .053"
43.0731	P325/19/0.40-0.64	19 mm / 3/4"	0.40-0.64 mm / .016 - .025"
43.0732	P325/19/0.65-1.05	19 mm / 3/4"	0.65-1.05 mm / .026 - .041"
43.0733	P325/19/1.06-1.35	19 mm / 3/4"	1.06-1.35 mm / .042 - .053"

## 8 ELECTRIC SCHEMATIC

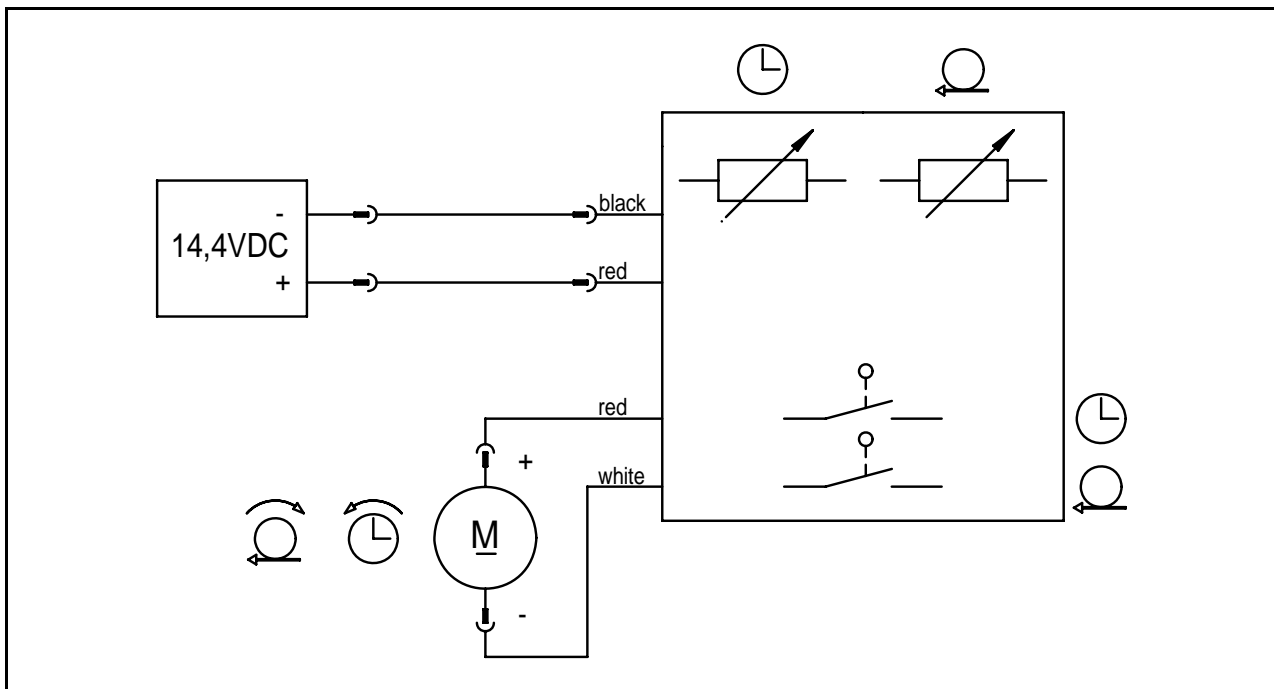

Distributed By:  
**Allstrap**  
 1719 Kenny Rd  
 Columbus, OH, 43212

## 9 EXCHANGE OF WEARING PARTS



Remove always the battery from the tool before starting maintenance works.

### 9.1 Exchange of tensioning wheel and grippers

#### Disassembling

- Unscrew end cover P35.3211 and remove it;
- Remove the torsion spring N2.5823;
- Remove the tensioning body;
- Remove the tensioning wheel together with the bearing N3.1172 from the tool;
- Unscrew the holders and remove them from the tensioning body;
- Remove the grippers from the tensioning body.

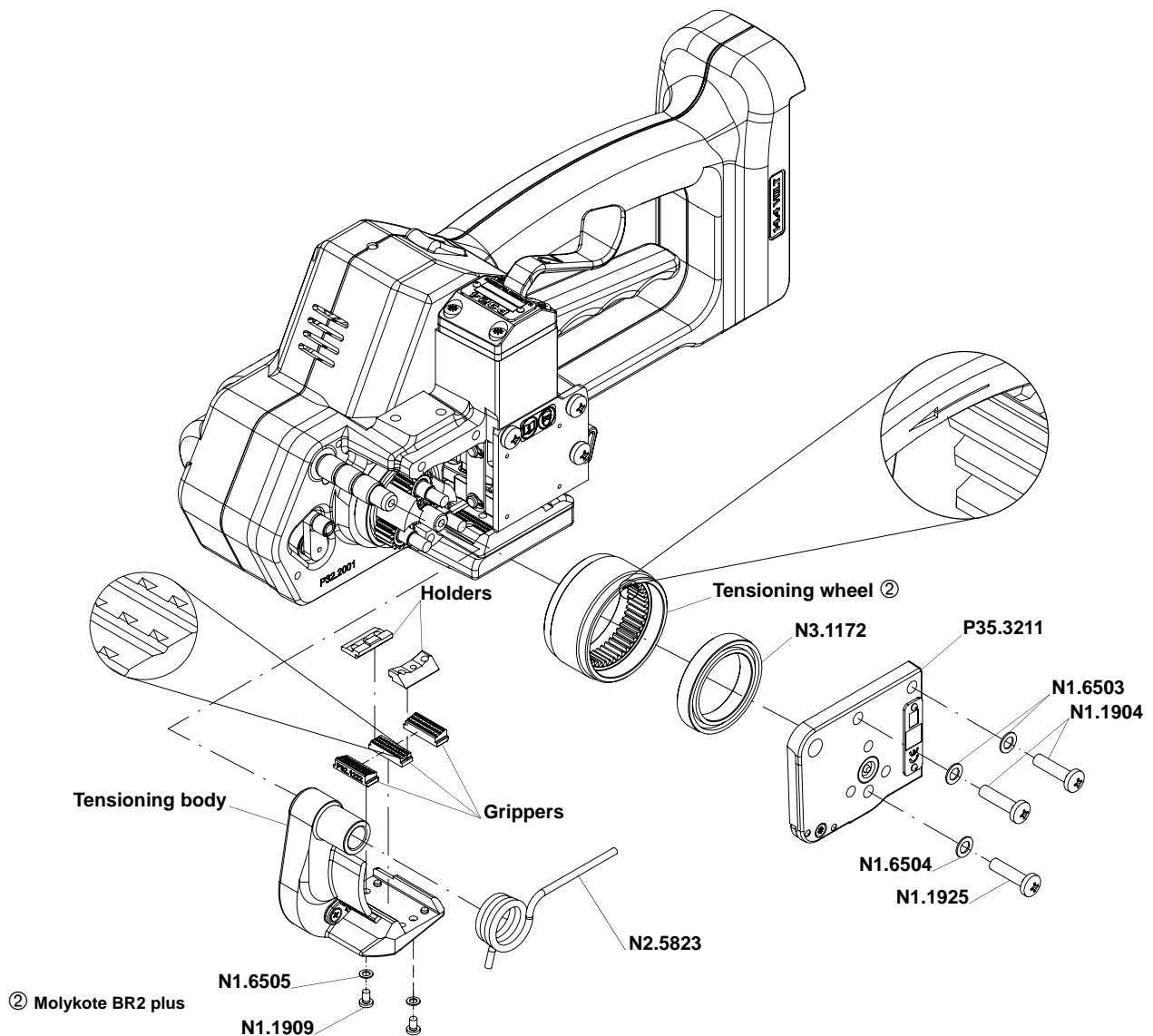

#### Assembling

Assembling in opposite order. Observe the following:

- Lubricate the internal tothing of the tensioning wheel with Molykote BR 2 plus.



**Observe the position of the tensioning wheel. The direction of rotation of the tensioning wheel is marked at the front of the tensioning wheel (see drawing). Observe the position of the grippers (see drawing).**



## 9.2 Exchange of cutter, welding stop gripper and welding gripper

### Disassembling

- Unscrew cover P32.2066 and remove it;
- Unscrew end cover P35.3211 and remove it;
- Remove the torsion spring N2.5823 and the tensioning body;
- Remove the tensioning wheel together with the bearing N3.1172 from the tool;
- Disassemble the security ring N2.1118 and remove the lever P32.1414 from the handle shaft;
- **Don't** loosen screw N1.1553 at the coupler P32.1251.
- Disassemble the security ring N2.1121 from the coupler, remove the coupler;
- Pull out the centering sleeve P32.1710 from the guide case P35.3215 to left, disassemble the guide case;
- Pull out the pressure spring with a screw driver from the cutter P35.3214;
- Remove the cutter from the driving pin P32.1032;
- Disassemble the screws N1.1305, lift slightly the welding stop gripper P35.3128 and the steel insert P35.3127 and remove them from the tool;
- Push the steel insert without welding stop gripper under the welding gripper P32.1511 until it touches the parallel pin N2.2110;
- Press down lever P32.2028, if the welding gripper does not sit on the steel insert, put a piece of plastic strap between welding gripper and steel insert.
- Disassemble the safety ring N2.1121 from the bolt P32.1028, remove the bolt from the welding gripper;
- Press in coupler P32.1410 in order to release the lever P32.2028 again;
- Pull out the steel insert with care to right under the welding gripper;
- Disassemble the security rings N2.1121 from the driving pin P32.1032, remove the driver P32.1035 from the driving pin;
- Lift the rocker P32.1510 behind the welding gripper with a screw driver, remove the welding gripper together with the ball cage P32.1027 and the balls N3.1702 from the tool;
- Lower the rocker, remove the thrust piece P32.1029 from the tool.

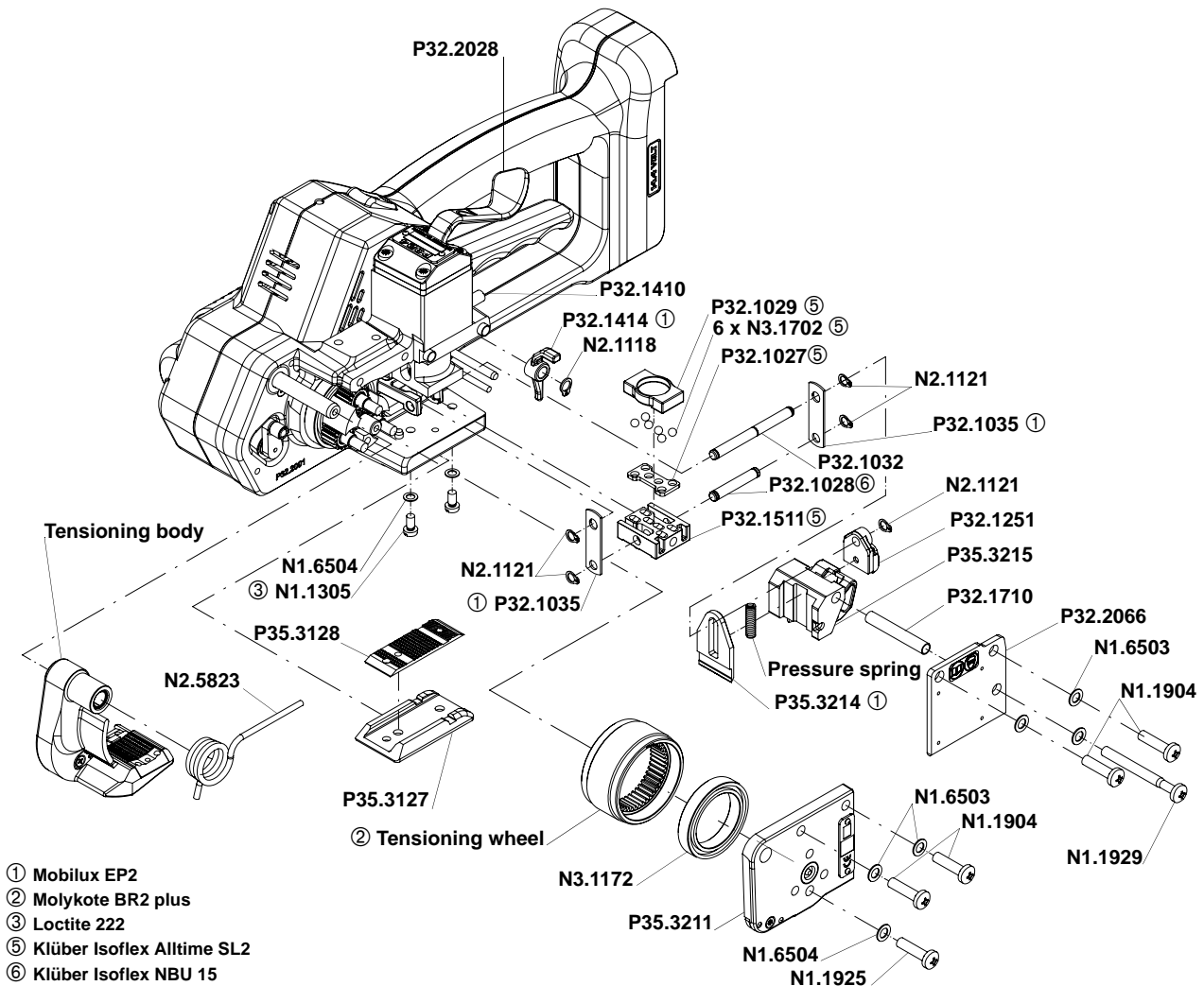



## Assembling

Assembling in opposite order. Observe the following:



**Pay attention to the fitting position of the cutter (see drawing).**

**Safe the screws N1.1305 with Loctite 222.**

**Observe the position of the tensioning wheel. The direction of rotation of the tensioning wheel is marked at the front of the tensioning wheel (see 9.1).**

## Lubrication

- Lubricate the rocker and the bolt P32.1028 in the area of the welding jaw with Klüber Isoflex NBU 15.
- Lubricate the balls, ball cage and the running surface of the balls on the welding gripper with Klüber Isoflex Alltime SL2.
- Lubricate the cutter and the driver with Mobilux EP2.
- Lubricate the internal toothing of the tensioning wheel with Molykote BR 2 plus.

## 9.3 Adjustment of the coupler

The coupler is adjusted in our works.

In case of replacing the seesaw lever, the coupler or the lever body, the coupler has to be readjusted.

Procedure as follows:

The battery is removed from the tool.

The coupler is fitted into the tool.

- Loosen screw N1.1553.
- Displace thrust piece, so that it touches the two seesaw levers without moving them.
- Retighten screw N1.1553.

### Control:

The thrust piece must touch the seesaw levers (X1).

Both guide pins must sit on the welding stop gripper (X2).

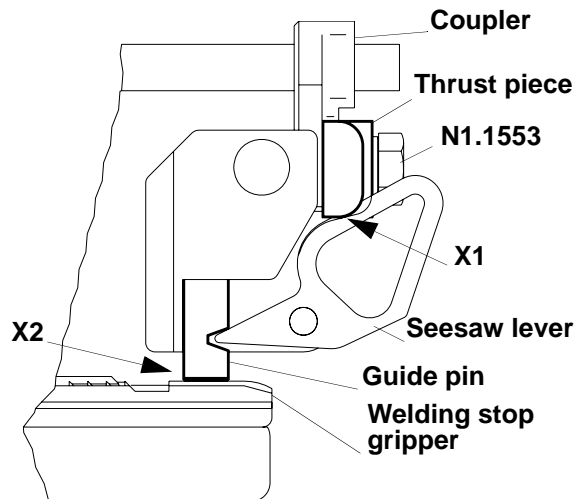

## 10 SERVICE

Servicing and repair work must only be carried out by authorized service centres.

If the tool breaks down or does no longer operate do not disassemble it. Send it fully assembled to the local service centre (see name and address on the rear page of this manual). Use original packing.

The battery powered plastic strapping tool P325 is a high performance tool. We strongly recommend you to have it serviced by an authorized service shop after 12 months at the latest if used one shift per day. If used two or more shifts per day the tool has to be serviced after a shorter period of time.

## 11 CLEANING

Clean strap gripping parts from strap abrasion regularly using compressed air (do not use any mechanical tool for cleaning).

When cleaning the surface of the tool do not use water or aggressive solvents!

## 12 WARRANTY CONDITIONS AND LIABILITY

FROMM Holding AG warrants all its strapping tools and machine heads during a period of 90 days from the date of sale. The warranty includes all deficiencies clearly resulting from poor manufacturing or faulty materials. Damage claims as a result of production shutdowns and claims for damage to persons and to property resulting from warranty deficiencies cannot be asserted by the customer.

The warranty excludes:

- wearing parts,
- deficiencies resulting from improper installing, incorrect handling and maintaining the tool,
- deficiencies resulting from using the tool without or with defective security- and safety devices,
- disregard of directions in the operation manual,
- arbitrary modifications of the tool,
- deficient control of wearing parts,
- deficient repair works of the tool.
- Use of consumable products not recommended by FROMM Holding AG

We reserve the right to modify the product at any time in order to improve its quality.

## 13 APPROPRIATE USE

The tool model P325 has been designed to strap packages with plastic strapping exclusively.

The warranty / liability excludes:

- non appropriate use of the tool,
- disregard of directions in the operation manual,
- disregard of control- and maintenance instructions.

Distributed By:

**Allstrap**

1719 Kenny Rd  
Columbus, OH, 43212

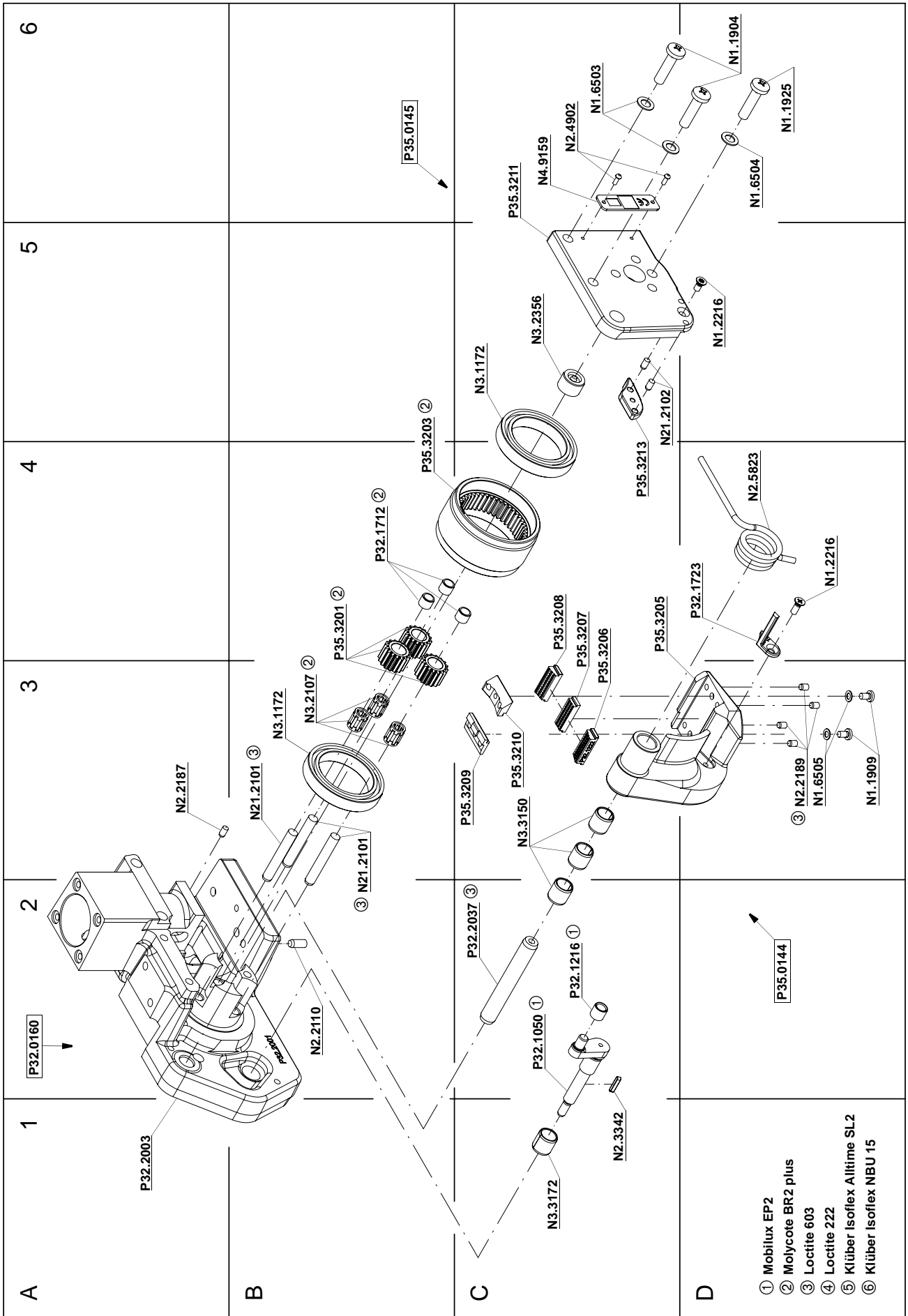

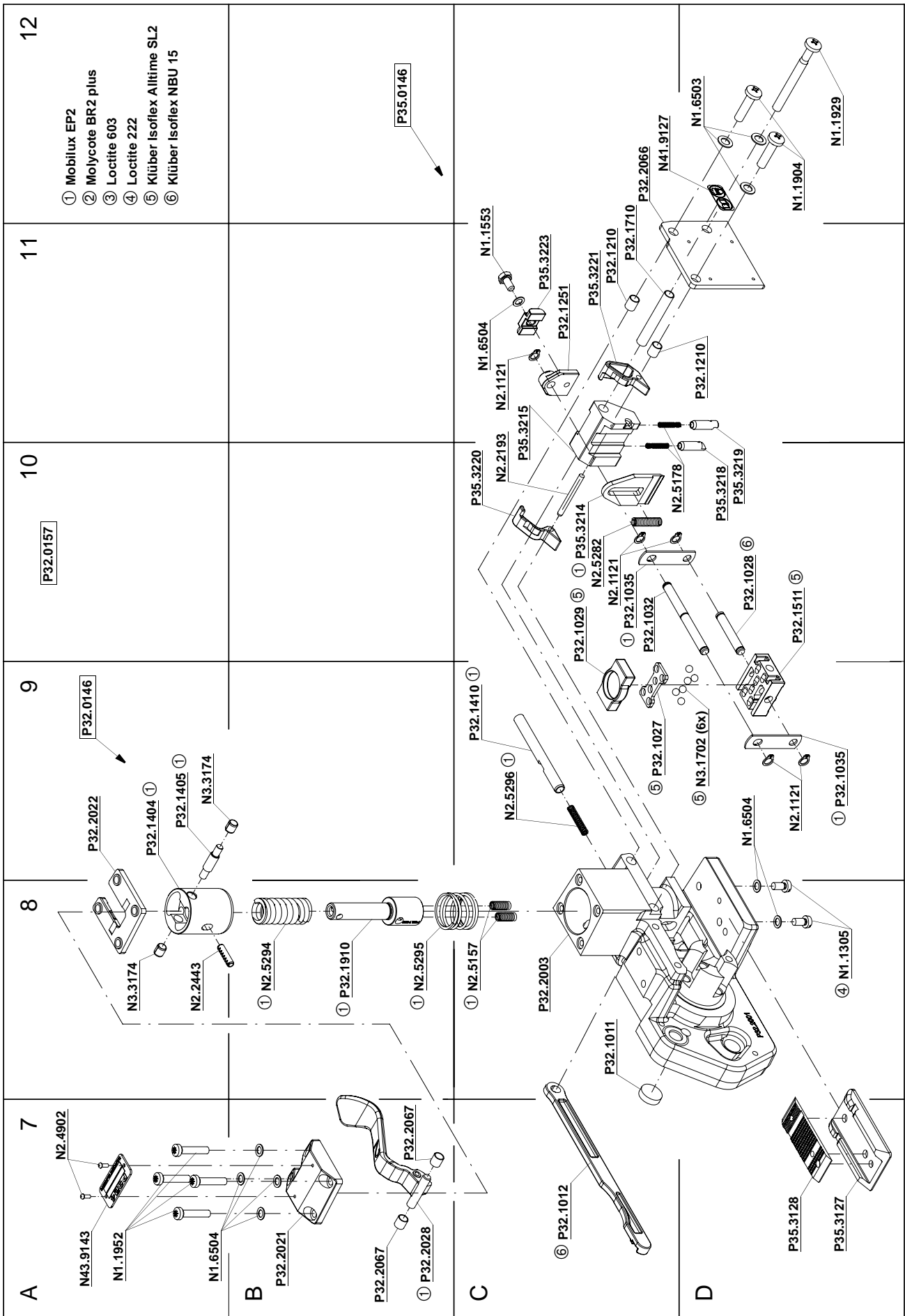

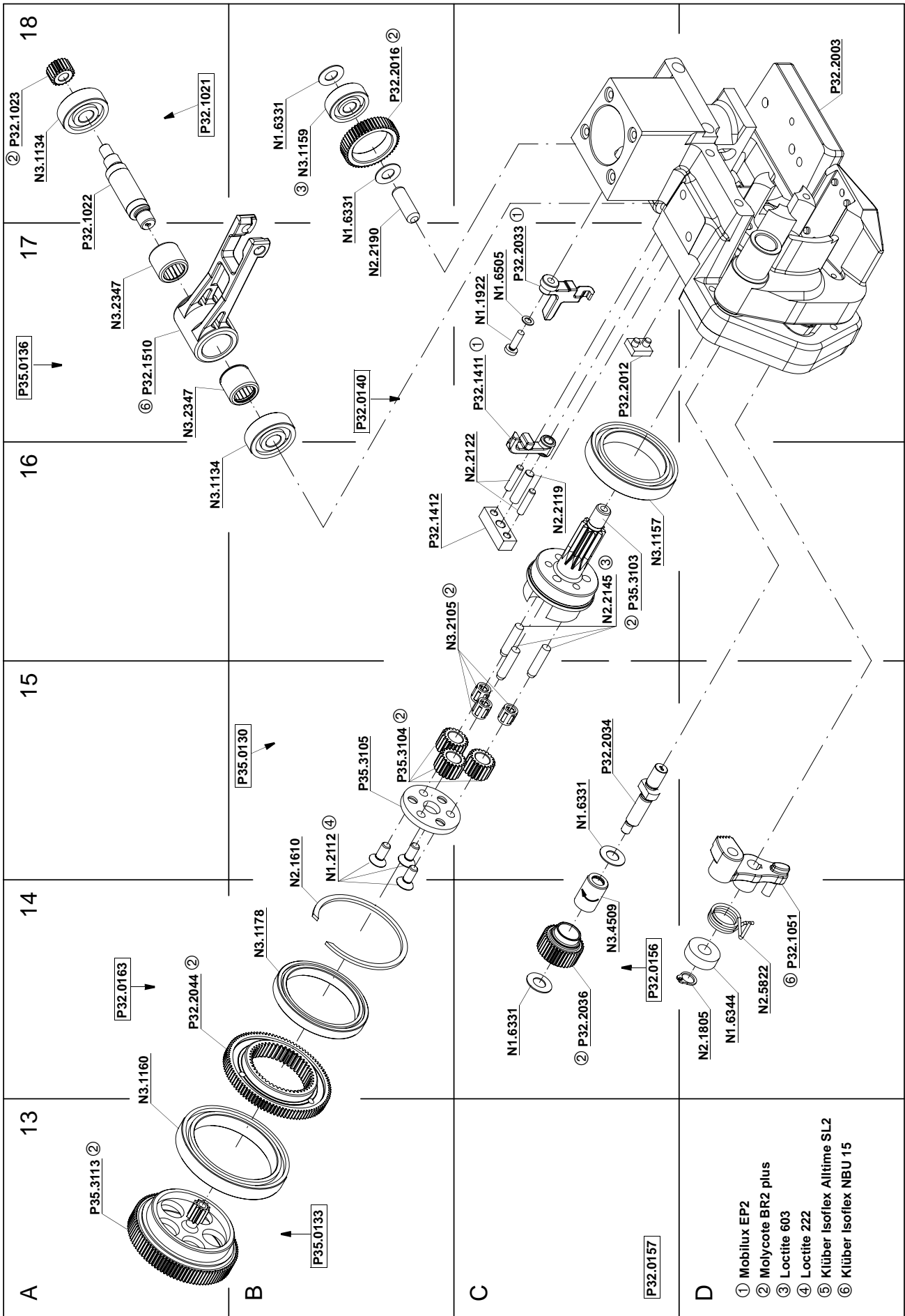

- D**
- ① Mobilux EP2
  - ② Molycote BR2 plus
  - ③ Loctite 603
  - ④ Loctite 222
  - ⑤ Klüber Isoflex Alltime SL2
  - ⑥ Klüber Isoflex NBU 15

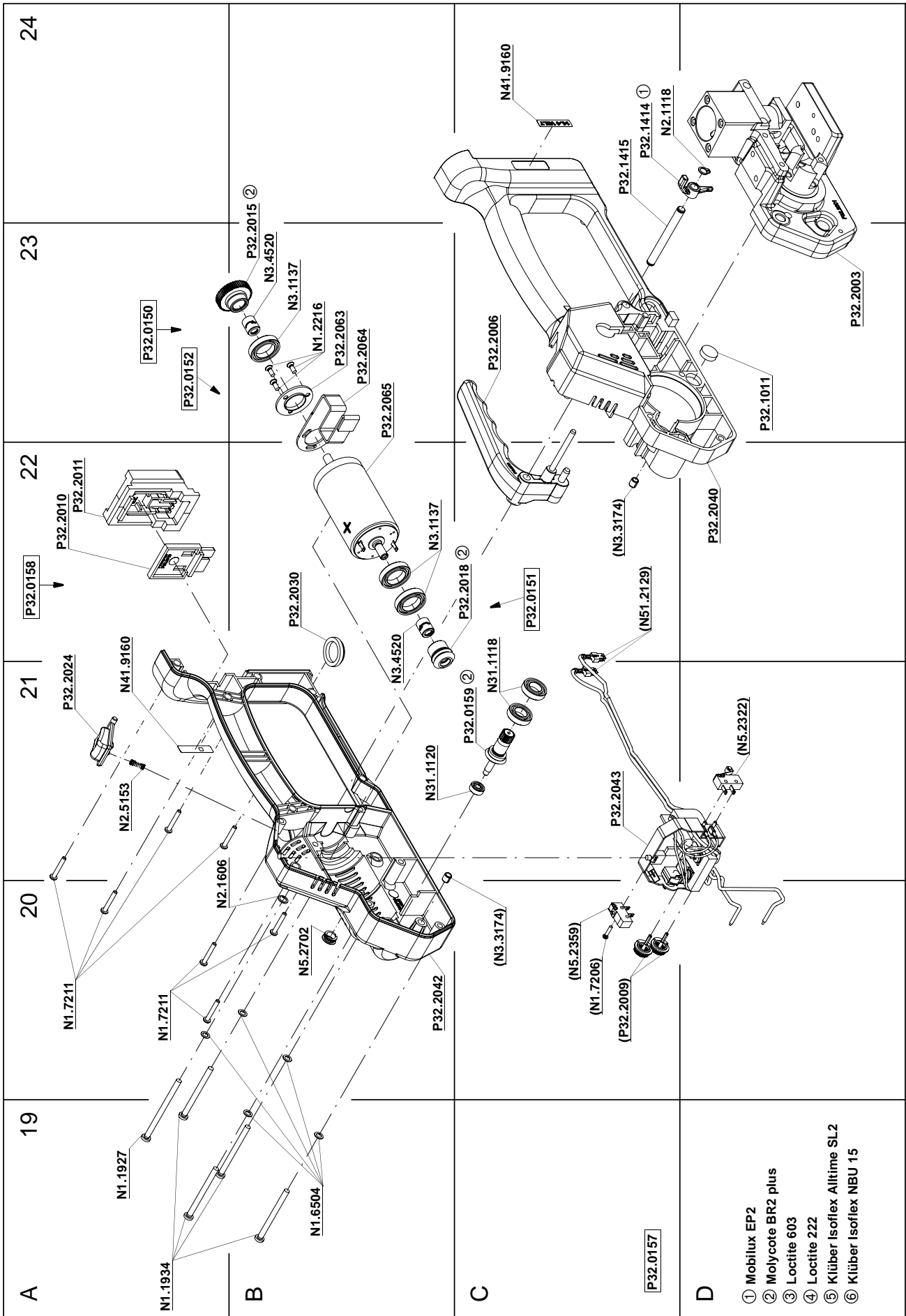

## 14 SPARE PARTS LIST 43.0733.01

43.0733.01	P325/19/1.06-1.35		P325.0001.01			04.07.06
Item-No.		in group	Pcs.	Description	Dimension	Field
N1.1305		P32.0157	2	SCREW	M4 X 7.8	D8
N1.1553		P35.0146	1	HEXAGON SCREW	M4 X 8	C11
N1.1904			4	SCREW	M5 X 20	D6+
N1.1909			2	FLAT HEAD SCREW	M3 X 5	D3
N1.1922		P32.0157	1	SCREW	M3 X 10	C17
N1.1925			1	SCREW	M4 X 20	D6
N1.1927		P32.0157	1	FLAT HEAD SCREW	M4 X 60	A19
N1.1929			1	SCREW	M5 X 50	D12
N1.1934		P32.0157	4	FLAT HEAD SCREW	M4 X 50	A19
N1.1952		P32.0157	4	FLAT HEAD SCREW	M4 X 20	A7
N1.2112		P35.0130	3	COUNTERSUNK SCREW	M4 X 10	B15
N1.2216			2	COUNTERSUNK SCREW	M3 X 8	D5+
N1.2216		P32.0152	3	COUNTERSUNK SCREW	M3 X 8	B23
N1.6331		P32.0157	4	SPACER WASHER	6 X 12 X 0.5	B18+
N1.6344		P32.0157	1	SPACER PIECE	6.3 X 15 X 5	D14
N1.6503			5	SAFETY WASHER	M5	C6+
N1.6504			1	SAFETY WASHER	M4	D6
N1.6504		P32.0157	11	SAFETY WASHER	M4	B19+
N1.6504		P35.0146	1	SAFETY WASHER	M4	C11
N1.6505			2	SAFETY WASHER	M3	D3
N1.6505		P32.0157	1	SAFETY WASHER	M3	C17
N1.7206		P32.2043	1	PT-SCREW	2.2 X 10	C20
N1.7211		P32.0158	7	PT-SCREW	3 X 20	A20
N21.2101		P32.0160	3	PARALLEL PIN	5 h6 X 40	B3
N21.2102		P35.0145	2	PARALLEL PIN	3 m6 X 8	C5
N2.1118		P32.0158	1	SECURITY RING	6	C24
N2.1121			1	SECURITY RING	5	C11
N2.1121		P32.0157	4	SECURITY RING	5	D9+
N2.1606		P32.0158	1	SPRING RING	SW6	A20
N2.1610		P32.0157	1	SPRING RING	SB44	B15
N2.1805		P32.0157	1	TENSIONING RING	6	D14
N2.2110		P32.0160	1	PARALLEL PIN	4 m6 X 10	B2
N2.2119		P32.0140	1	PARALLEL PIN	4 m6 X 18	C16
N2.2122		P32.0140	2	PARALLEL PIN	3 h6 X 14	C16
N2.2145		P35.0130	3	PARALLEL PIN	4 h6 X 18	C16
N2.2187		P32.0160	1	PARALLEL PIN	3 m6 X 6	A3
N2.2189		P35.0144	4	PARALLEL PIN	3 m6 X 5	D3
N2.2190		P32.0157	1	PARALLEL PIN	6 h6 X 18	B17
N2.2193			1	PARALLEL PIN	3 m6 X 32	C10
N2.2443		P32.0146	1	DOWEL PIN	4 X 15	A8
N2.3342		P32.0157	1	FEATHER KEY	2 X 2 X 10	C1
N2.4902			2	HAMMER HEAD BOLT	1.85 X 4.76	C6
N2.4902		P32.0157	2	HAMMER HEAD BOLT	1.85 X 4.76	A7
N2.5153		P32.0158	1	PRESSURE SPRING	0.4 X 4.1 X 16/10.5	A21
N2.5157		P32.0157	2	PRESSURE SPRING	0.6 X 4.8 X 20/15.5	C8
N2.5178			2	PRESSURE SPRING	0.32 X 2.82 X 20.5/ 20.5	C10
N2.5282			1	PRESSURE SPRING	0.8 X 4.8 X 27/17.5	C10
N2.5294		P32.0146	1	PRESSURE SPRING	2.5 X 15 X 46.5/9.5	B8
N2.5295		P32.0157	1	PRESSURE SPRING	1.5 X 21 X 27/5.5	B8
N2.5296		P32.0157	1	PRESSURE SPRING	0.5 X 4 X 24/16.5	C9

[ ] = Group

\* = Wearing parts



43.0733.01	P325/19/1.06-1.35		P325.0001.01			04.07.06
Item-No.		in group	Pcs.	Description	Dimension	Field
N2.5822		P32.0157	1	TORSION SPRING	1.25 X 12/3.75	D14
N2.5823			1	TORSION SPRING	2.8 X 17/4	D4
N31.1118		P32.0158	2	BALL BEARING	10 X 19 X 5	C21
N31.1120		P32.0158	1	BALL BEARING	4 X 11 X 4	B21
N3.1134		P32.0157	1	BALL BEARING	7 X 22 X 7	A16
N3.1134		P32.1021	1	BALL BEARING	7 X 22 X 7	A18
N3.1137		P32.0150	1	BALL BEARING	15 X 24 X 5	B23
N3.1137		P32.0158	2	BALL BEARING	15 X 24 X 5	B22
N3.1157		P35.0130	1	BALL BEARING	30 X 42 X 7	C16
N3.1159		P32.0157	1	BALL BEARING	6 X 19 X 6	B18
N3.1160		P35.0133	1	BALL BEARING	40 X 52 X 7	A14
N3.1172			2	BALL BEARING	30 X 42 X 7	B3+
N3.1178		P32.0163	1	BALL BEARING	35 X 44 X 5	B14
N3.1702		P32.0157	6	BALL	4 MM	D9
N3.2105		P35.0130	3	NEEDLE CAGE	K 4 X 7 X 7 TN	B16
N3.2107			3	NEEDLE CAGE	K 5 X 9 X 13 TN	B3
N3.2347		P35.0136	2	NEEDLE BUSH	10 X 14 X 12	A17
N3.2356		P35.0145	1	NEEDLE CASE	7 X 11 X 9	C5
N3.3150		P35.0144	3	SLIDE-BEARING	8 X 10 X 12	C3
N3.3172		P32.0160	1	SLIDE-BEARING	8 X 10 X 10	C1
N3.3174		P32.0146	2	SLIDE-BEARING	4 X 5.5 X 6	A8+
N3.3174		P32.2040	1	SLIDE-BEARING	4 X 5.5 X 6	C22
N3.3174		P32.2042	1	SLIDE-BEARING	4 X 5.5 X 6	C20
N3.4509		P32.0156	1	NEEDLE FREE WHEELING	6 X 10 X 15	C14
N3.4520		P32.0150	1	FREE-WHEELING	6 X 10 X 12	B23
N3.4520		P32.0151	1	FREE-WHEELING	6 X 10 X 12	B22
N41.9127			1	ADHESIVE LABEL	20 X 10 X 0.1	C12
N41.9160		P32.0158	2	ADHESIVE LABEL	14.4 VOLT	A21+
N43.9143		P32.0157	1	TYPE PLATE	<<P325>>	A7
N4.9159			1	LABEL	<<CE>>	C6
N51.2129		P32.2046	1	CONTACT PLUG		C22
N51.2129		P32.2048	1	CONTACT PLUG		C22
N5.2322		P32.2043	1	MICRO SWITCH		D21
N5.2359		P32.2043	1	MICRO SWITCH		C20
N5.2702		P32.0158	1	COVER		B20
[P32.0140]		P32.0157	1	INSERTATION PART		B17
[P32.0146]		P32.0157	1	SPRING PACKAGE		A9
[P32.0150]		P32.0158	1	SPUR WHEEL		A23
[P32.0151]		P32.0158	1	CONICAL GEAR WHEEL		C22
[P32.0152]		P32.0158	1	MOTOR		A23
[P32.0156]		P32.0157	1	SPUR WHEEL		C14
[P32.0157]			1	BASE MODEL		A10+
[P32.0158]		P32.0157	1	DRIVE		A22
[P32.0159]		P32.0158	1	PINION		C21
[P32.0160]		P32.0157	1	BODY		A2
[P32.0163]		P32.0157	1	WHEEL		A14
P32.1011		P32.0157	1	FELT		C8
P32.1011		P32.0158	1	FELT		D23
P32.1012		P32.0157	1	COUPLER		C7
[P32.1021]		P32.0157	1	WELDING EXCENTRIC		A18
P32.1022		P32.1021	1	WELDING EXCENTRIC		A18
P32.1023		P32.1021	1	PINION		A18
P32.1027		P32.0157	1	BALL CAGE		C9

[ ] = Group

\* = Wearing parts



43.0733.01	P325/19/1.06-1.35		P325.0001.01		04.07.06	
Item-No.		in group	Pcs.	Description	Dimension	Field
P32.1028		P32.0157	1	BOLT		D10
P32.1029		P32.0157	1	THRUST PIECE		C10
P32.1032		P32.0157	1	DRIVING PIN		C10
P32.1035		P32.0157	2	DRIVER		D9+
P32.1050		P32.0157	1	FRONT TOGGLE LINK		C2
P32.1051		P32.0157	1	LEVER		D14
P32.1210			2	CENTERING SLEEVE		C11+
P32.1216			1	PRESSURE ROLLER		C2
P32.1251		P35.0146	1	COUPLER		C11
P32.1404		P32.0146	1	SPRING SLIDE		A9
P32.1405		P32.0146	1	ROLLER		A9
P32.1410		P32.0157	1	COUPLER		C9
P32.1411		P32.0157	1	LEVER		C17
P32.1412		P32.0140	1	INSERTATION PART		B16
P32.1414		P32.0158	1	LEVER		C24
P32.1415		P32.0158	1	HANDLE SHAFT		C24
P32.1510		P35.0136	1	ROCKER		A17
P32.1511	*	P32.0157	1	WELDING GRIPPER		D10
P32.1710			1	CENTERING SLEEVE		C11
P32.1712			3	DOWEL		B4
P32.1723			1	STRAP STOP		D4
P32.1910		P32.0146	1	SPRING BOLT		B8
P32.2003		P32.0160	1	BODY		A1+
[P32.2006]		P32.0158	1	HANDLE LEVER		C23
P32.2009		P32.2043	2	TURNING BUTTON		C20
P32.2010		P32.0158	1	COVER		A22
P32.2011		P32.0158	1	INSERTATION PART		A22
P32.2012		P32.0157	1	GUIDE		C17
P32.2015		P32.0150	1	SPUR WHEEL		B23
P32.2016		P32.0157	1	SPUR WHEEL		B18
P32.2018		P32.0151	1	CONICAL GEAR WHEEL		C22
P32.2021		P32.0157	1	COVER		B7
P32.2022		P32.0157	1	FIXING PLATE		A9
P32.2024		P32.0158	1	PRESSURE BUTTON		A21
[P32.2028]		P32.0157	1	LEVER		B7
P32.2030		P32.0158	1	DISK		B22
P32.2033		P32.0157	1	HOOK		C17
P32.2034		P32.0157	1	SHAFT		C15
P32.2036		P32.0156	1	SPUR WHEEL		C14
P32.2037		P32.0160	1	SWIVEL SHAFT		C2
[P32.2040]		P32.0158	1	MOTOR HOUSING		D22
[P32.2042]		P32.0158	1	MOTOR HOUSING		B20
[P32.2043]		P32.0158	1	CIRCUIT BOARD		C21
P32.2044		P32.0163	1	WHEEL		A14
P32.2063		P32.0152	1	DISK		B23
P32.2064		P32.0152	1	STEEL SHEET		B23
[P32.2065]		P32.0152	1	ELECTRIC MOTOR		B23
P32.2066			1	COVER		C12
P32.2067		P32.0157	2	CENTERING SLEEVE		B7
[P35.0130]		P32.0157	1	IDLER STEP		B15
[P35.0133]		P32.0157	1	SPUR WHEEL		B13
[P35.0136]		P32.0157	1	ROCKER		A17
[P35.0144]			1	TENSIONING BODY		D2

[ ] = Group

\* = Wearing parts

43.0733.01	P325/19/1.06-1.35		P325.0001.01			04.07.06
Item-No.		in group	Pcs.	Description	Dimension	Field
[P35.0145]			1	END COVER		B6
[P35.0146]			1	COUPLER		B12
P35.3103		P35.0130	1	PLANET SHAFT		C16
P35.3104		P35.0130	3	IDLER GEAR		B15
P35.3105		P35.0130	1	COVER		B15
P35.3113		P35.0133	1	SPUR WHEEL		A13
P35.3127		P32.0157	1	STEEL INSERT		D7
P35.3128	*	P32.0157	1	WELDING STOP GRIPPER		D7
P35.3201			3	IDLER GEAR		B4
P35.3203	*		1	TENSIONING WHEEL		B4
P35.3205		P35.0144	1	TENSIONING BODY		C4
P35.3206	*		1	GRIPPER		C4
P35.3207	*		1	GRIPPER		C4
P35.3208	*		1	GRIPPER		C4
P35.3209			1	HOLDER		C3
P35.3210			1	HOLDER		C3
P35.3211		P35.0145	1	END COVER		C6
P35.3213			1	STRAP GUIDE		C4
P35.3214	*		1	CUTTER		C10
P35.3215			1	GUIDE CASE		C11
P35.3218			1	GUIDE PIN		D10
P35.3219			1	GUIDE PIN		D10
P35.3220			1	SEESAW LEVER		C10
P35.3221			1	SEESAW LEVER		C11
P35.3223		P35.0146	1	THRUST PIECE		C11

[ ] = Group

\* = Wearing parts

Distributed By:  
**Allstrap**  
 1719 Kenny Rd  
 Columbus, OH, 43212