

Order from Allstrap 866-779-2673

PneumoLash

pneumatic tensioner for
cord and composite strap
up to 50 mm

LCV Stock no. 089192

FIRST

read these
instructions

Operating Instructions and Spare Parts List

CE

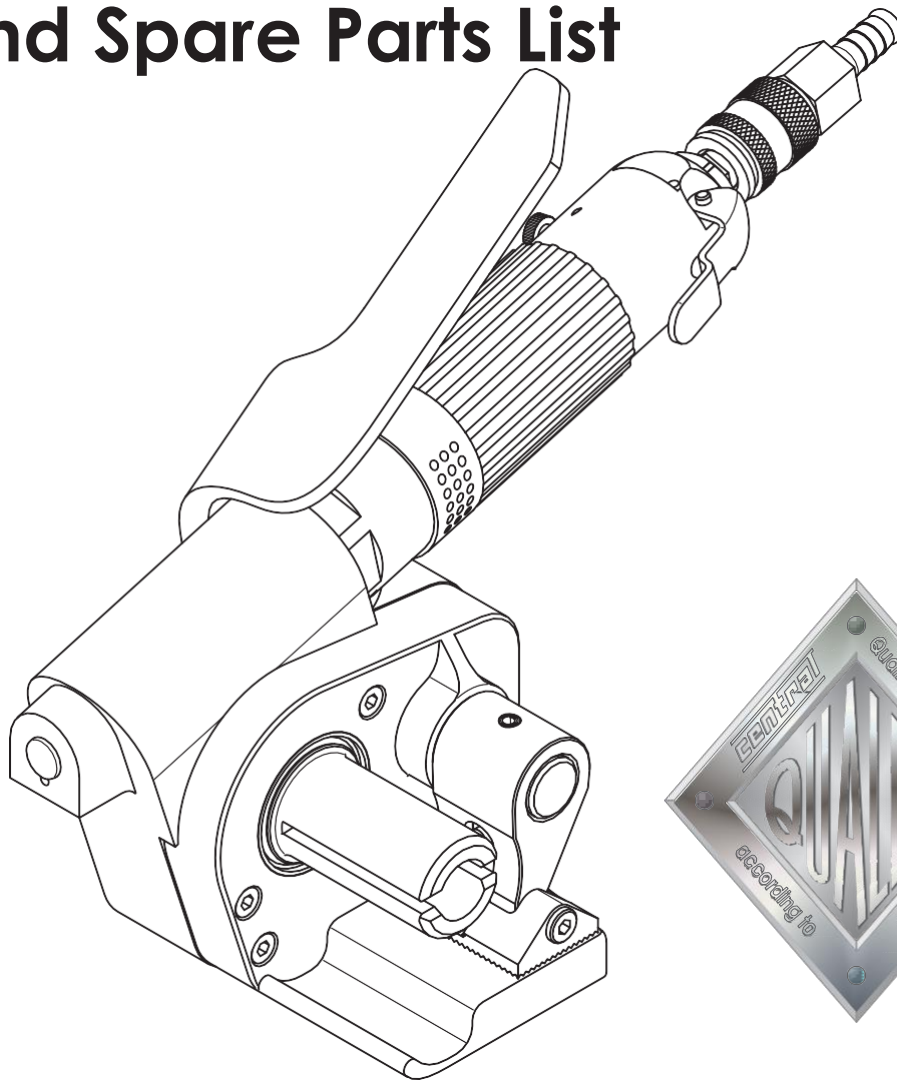

GREINER
VERPACKUNGSGERÄTE



Do not destroy these operating instructions! The customer is obliged to make these operating instructions available to all operators and service personnel and to ascertain that these persons understand the contents.

Adhere to safety instructions and warnings! Erroneous operation may cause serious injuries!

central

Field of Application for the *PneumoLash*

The PneumoLash central strapping tool is suitable exclusively for strapping all kinds of goods to be packaged, for securing cargo load units respectively using conventional cord and composite strap.

Warning and Safety Recommendations



Use safety glasses with lateral guards and protective gloves during cutting operations while working with strapping tools for cord and composite strap.



Do not put your hand or any other parts of your body between the strap and the piece to be packaged while operating the strapping tool.



The strap may tear while tensioning! Do not stand within the flight of the strap.



Hold the upper part in your hand while you cut the strap, and place yourself outside this range.

Caution: The lower strap end will spring up; Use safety strap shears!



Use only original central spare parts.

Suitable Cord and Composite Strap and Buckles

Use commercial size **textile and composite strap** 0.5 to 2.4 mm thick and 50 mm (2") max. wide exclusively.

Use commercial type **locking buckles** of suitable size only. The buckles must be used together with the proper textile or composite strap as released by the strap producer.

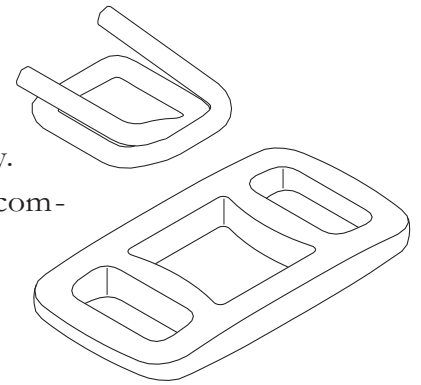

Compressed Air Supply Requirements

However, the maximum air pressure of 700 kPa / 7.0 bar (100 psi) must not be exceeded in any case. For trouble-free operation the compressed air supply should deliver 700 l/min minimum.

Safe and reliable operation is ensured by installing an air filter and oiler into the feed air line within a distance of 10 m ahead of the motor. We also recommend to integrate a pressure regulator into the compressed air conditioning unit. It keeps the desired operating pressure constant and simultaneously serves for the performance regulation so that the motor performance is exactly adjusted to the strapping requirements.

The maximum possible tension for the respective strapping operation should be preset via the pressure control valve. The below table quotes reference values as to the strap tension plus required compressed air feed with regard to the respective operating pressure.

Operating pressure of applied compressed air feed		Maximum obtainable strap tension	Compressed air consumption (appr.)
SI	ANSI		
200 kPa / 2.0 bar	29 psi	2.5 kN	230 l/min
300 kPa / 3.0 bar	43 psi	3.5 kN	280 l/min
400 kPa / 4.0 bar	58 psi	5.0 kN	330 l/min
500 kPa / 5.0 bar	72 psi	6.0 kN	380 l/min
600 kPa / 6.0 bar	87 psi	6.4 kN	470 l/min
700 kPa / 7.0 bar	100 psi	7.5 kN	610 l/min

Table 1: Strap tension in dependence of pressure, compressed air consumption

The conditioning unit and compressed air feed line should be selected so as to ensure sufficient flow cross-sections for a minimum pressure drop to ensure that the motor will put out its full capacity. We recommend the use of the FESTO® Type

FRC-3/8-D-5M-MINI conditioning unit. For connecting the compressed air supply a hose with 9 mm clear width should be used and connected to the unit using the coupling 005-720, which comes with the set. For minimum pressure drop the air feed hose must not be longer than 10 m.

Motor Lubrication

In order to guarantee optimal life and performance the air motor requires appr. $21 \text{ mm}^3/\text{min}$ oil. Insufficient lubrication leads to faster vane wear and reduced performance. For the required quantity of oil the mist oiler in the conditioning unit must be set to deliver one drop of oil appr. every 45 seconds with continuous motor operation (one drop of oil corresponds to appr. $15 \text{ mm}^3/\text{min}$). For long life and optimal performance with the corresponding operating temperatures the oils used should fulfil the below listed requirements:

Ambient Temperature	Oil Type	Example
less than 5°C	ISO VG 46 / DIN 51502 DL 46	EA 60 S
5°C – 35°C	ISO VG 150 / DIN 51502 DL 150	Almo [®] 525
25°C – 60°C	ISO VG 32 / DIN 51502 PGL 32	Almo [®] 529

Table 2: Released oil types

Accessories for *PneumoLash*

Your central dealer and service partner holds the below listed accessories in store for you to usefully complete your PneumoCord strapping tool:

- **Suspender (Stock no. 040-900)**

The suspender (040-900) permits to hang up your PneumoLash strapping tool on a balancer, giving the tool a stable balance in various orthogonal positions: PneumoLash in horizontal position (refer to illustration) turned 90° about the fixing point of the suspender; in vertical position with motor pointing downward permitting free turning of the unit within a range between 0 and 90° relative to the suspender.

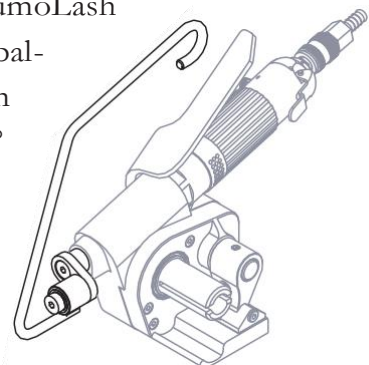

- **Hose unit (Stock no. 089901)**

consisting of: 10 m RectuSoft - PVC 9.0 x 14.5 mm hose, 25KA TF09 MPN clutch, GT17/09N screw socket mounted via KB1417 two-ear hose clips. Connection of the PneumoCord to the service unit.

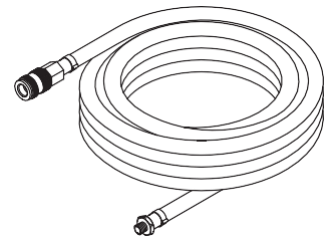

- **Service unit (Stock no. 089900)**

FRC-3/8-D-5M-MINI

Filter-pressure-control valve-oiler combination, 5µm filter with metal protective basket and manual condensate drain.

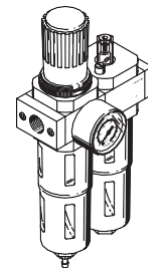

Mounting the Locking Buckle

Depending on the type of buckle, different methods can be used to thread the cord and composite strap into the locking buckle.

Option I can be used for buckles with open ends. **Option II** can be used for closed buckles.

Decisive for the method applied for strap mounting are the details furnished by the producer of the locking buckle used in combination with the cord or composite strap applied.

Option I

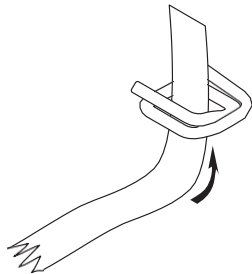

1. Placing strap end into buckle

The locking buckle ends must point upward and away from the operator. Run the strap end from the bottom through the buckle opening.

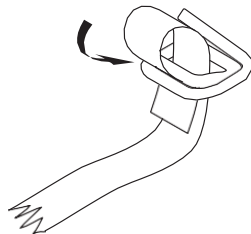

2. Inserting the strap end into the buckle

Run the strap end around the buckle end located left from the operator and lead it through the distance between the buckle end and lower located buckle winding.

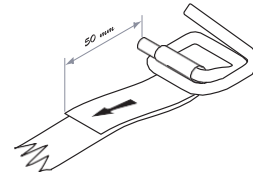

3. Termination of strap end mounting

Lead strap end through the buckle until it protrudes over the buckle 50 mm minimum. Now run the strap around the package or around the cargo unit to be secured.

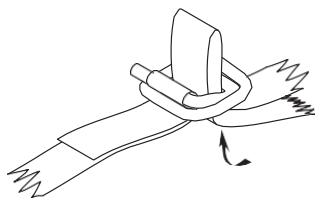

4. Inserting strap loop into buckle

Bend over strap and place bent portion from lower end through buckle opening.

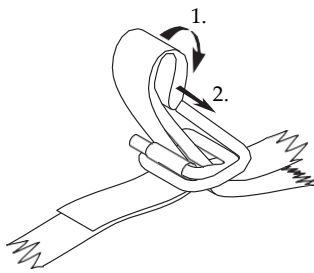

5. Mounting strap loop in buckle

First bend folded portion approx. 180° around the right-hand buckle end and then slide it over buckle end.

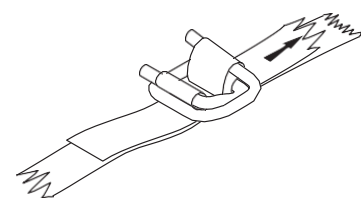

6. Tightening the strap

Manually tighten the upper strap portion retaining the lower portion of the strap ensuring that the buckle is not displaced.

Option II

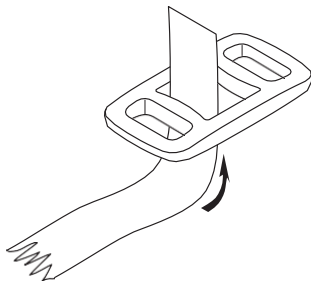

1. Placing the first strap end into the buckle

Run the first strap end from below through the middle buckle opening.

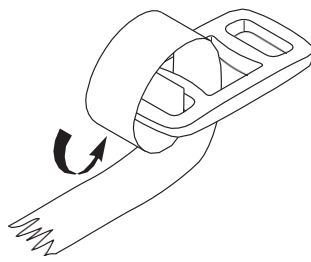

2. Inserting the strap end - first step

Run the strap end from below around the buckle opening located left of the operator.

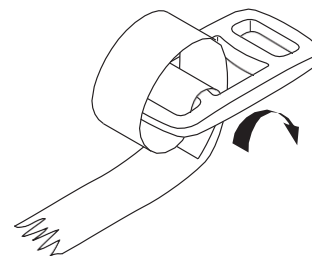

3. Inserting the strap end - second step

Now push the strap end from above through the middle opening.

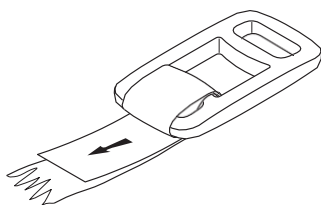

4. Tightening the strap

Pull the strap leaving the locking buckle so that strap loop closes around the buckle.

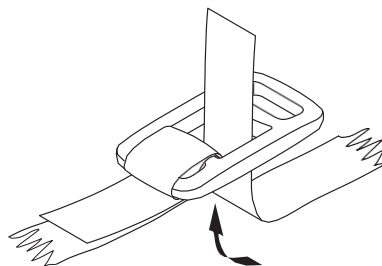

5. Placing the second strap end into the buckle

Run the strap around the package or item to be secured and place the second strap end from below into the middle buckle opening.

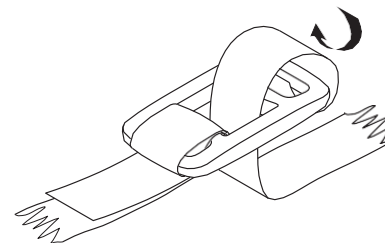

6. Inserting the strap end - first step

Run the strap end from below around the buckle opening located right of the operator.

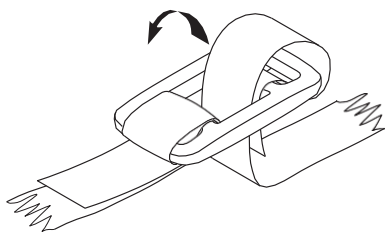

7. Inserting the strap end - second step

Now push the strap end from above through the middle opening.

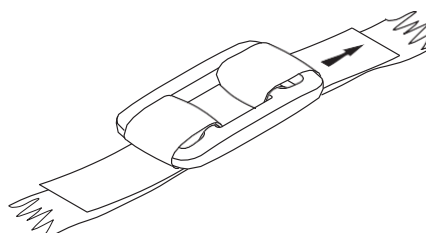

8. Tightening the strap

Pull the strap leaving the locking buckle so that strap loop closes around the buckle.

Operation

of the central strapping tool *PneumoLash*
LCV

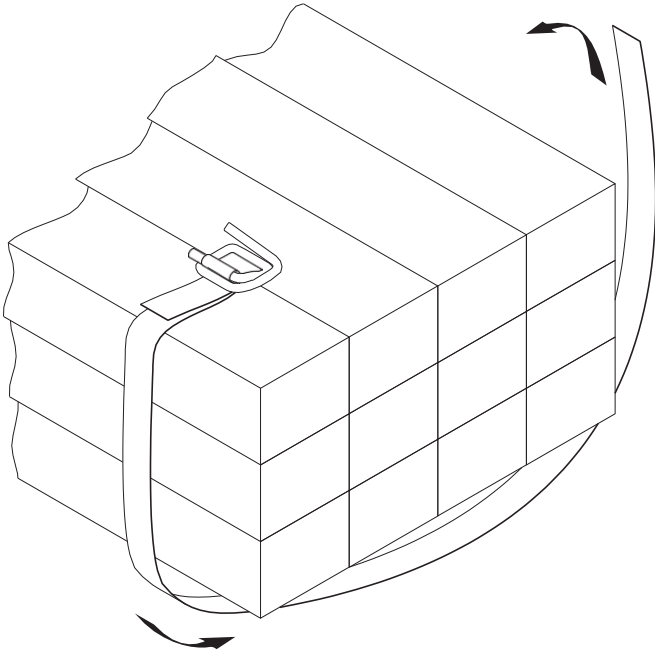

1. Mounting strap in locking buckle

First the strap is cut to the required length. The length of strap should be long enough to reach around the item at the position to be strapped and there should be an overhang of at least 50 cm.

Now the end of the cord or composite strap is fixed to the buckle end located left of the operator according to the buckle manufacturer's instructions.

Then run the strap around the package or cargo unit to be secured.

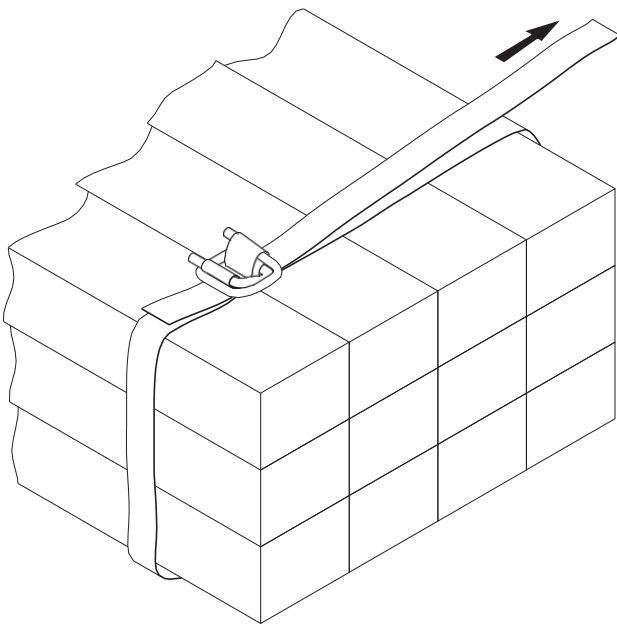

2. Sealing locking loop

No insert the strap into the locking buckle on the right end of the buckle according to the locking buckle manufacturer's instructions.

Tighten strap by pulling at the upper strap end and simultaneously manually arresting the lower strap end.

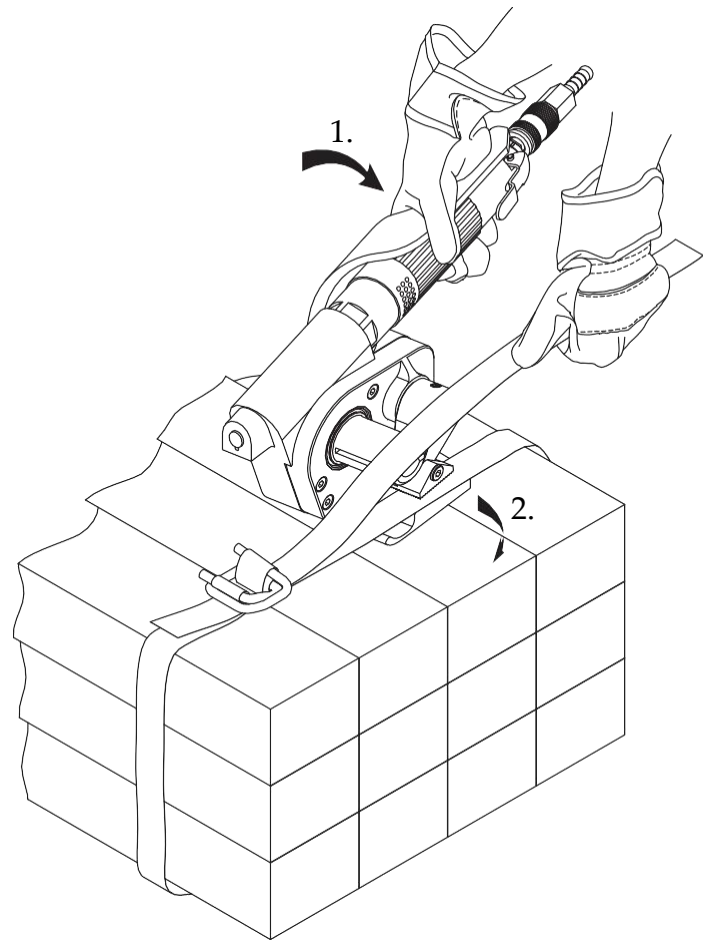

3. Placing the strapping tool onto the strap.

Hold the free strap end with your left hand and press down the lever with your right hand toward the tool motor.

Now slide the strapping tool from right to left onto the piece of strap up to the stopper which is lying on the item to be strapped.

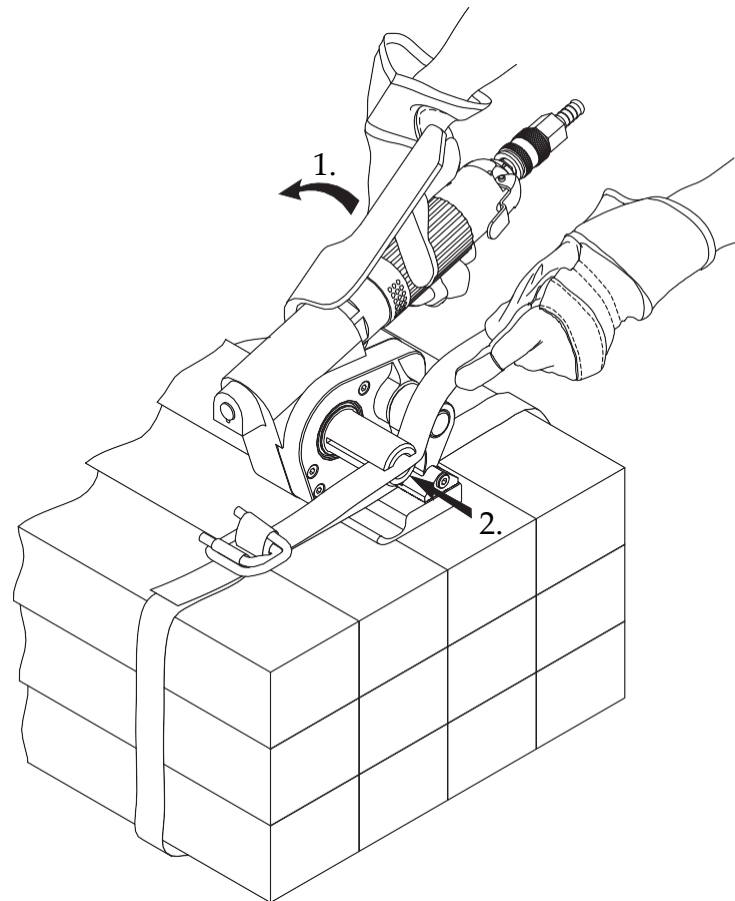

4. Inserting the strap

Slowly release the tool lever in upward direction.

Next place the piece of strap lying on top in the slot of the winding shaft up to the stopper.

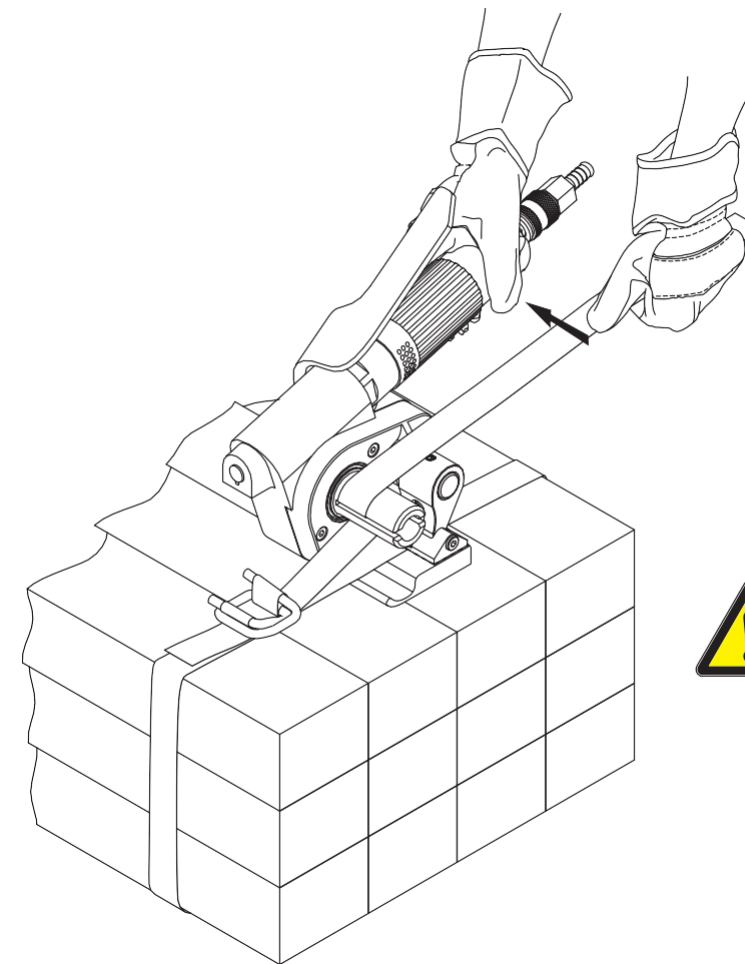

5. Strap tensioning

Now, the left hand guides the strap. The right hand holds the tool motor and depresses the lever at its rear left end until the desired tension has been obtained.

In order to obtain a repeatable strap tension the operating pressure of the unit may be so adjusted that the desired strap tension is reached when the motor comes to its standstill.



Caution: The strap may rupture and cause injuries if the operating pressure is excessively high for the strap chosen or if the strap has an insufficient tensile strength.

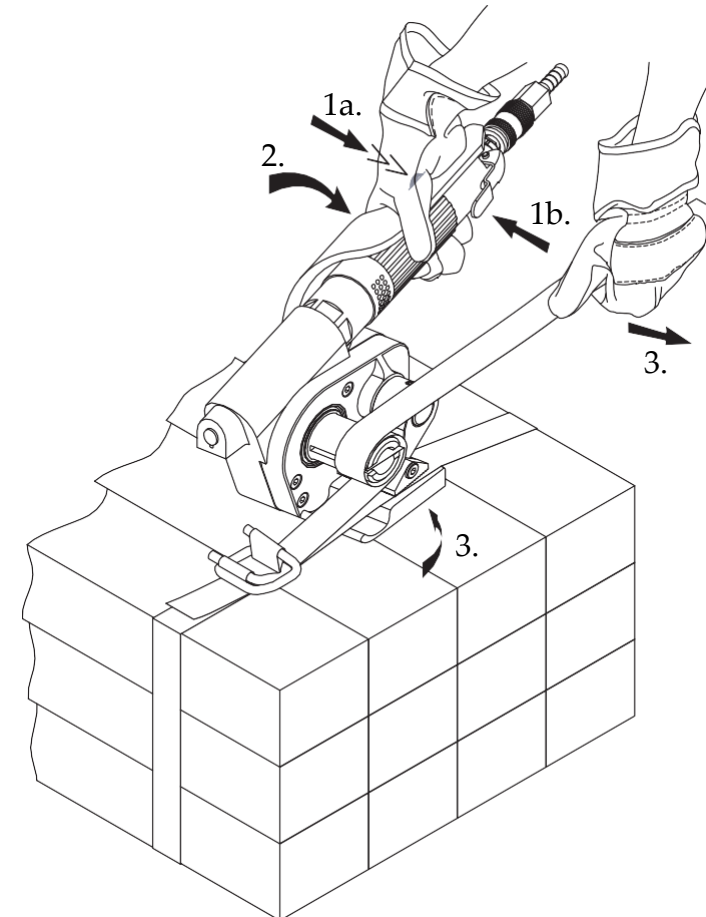

6. Releasing the tool

After completing the tensioning first press the button on the right side of the motor and then additionally the control lever on the left side. The winding shaft is thereby retracted, and the strap wrapped around it is released.

Now press down the lever down towards the motor. Then pull the tool to the right out of the strap that has been made.

The strap end remaining on the winding shaft may be removed without any tool.

PneumoLash Maintenance

The clamp plate 040-053 requires daily cleaning from strap residue either by compressed air, wire brush or another suitable mechanical accessory. More frequent cleaning may be indicated depending on the strap used or frequency of application.

Otherwise the PneumoLash strapping tool requires no service. However, for repair work the repair instructions at the end of these operating instructions should be adhered to.

During the warranty period repairs performed by unauthorised persons will cease the guaranty of the manufacturer.

Hints for Repair

With repair work, the sliding and bearing points as well as the components within the drive housing and worm gear unit plus ball bearing must be regreased with sufficient liquid grease. Authorised is UNIGEAR® LA02.

Components secured with LOCTITE® 270 according to the spare parts list require replacement of the LOCTITE® 270 seal if this material has been removed during repair.

Repair of compressed air vane motor 038-190

Repairs of compressed air vane motors must be done by central authorised shops exclusively. The operator or other unauthorised persons must not open the motor nor disassemble it.

During the warranty period repairs performed by unauthorised persons will cease the guaranty of the manufacturer.

Specifications

- *Length/width/height:*
305 x 135 x 225 mm
- *Weight:*
4.35 kg
- *Seal:*
Friction lock with buckle
- *Compressed air:*
maximum 700 kPa / 7.0 bar (100 psi), maximum 610 1/min
- *For cord and composite strap, buckle:*
10 – 50 mm ($\frac{3}{8}$ " – 2"), thickness 0.5 up to 2.4 mm max.;
Locking buckle as per recommendation of the strap manufacturer

Distributed By:
Allstrap
1719 Kenny Rd
Columbus, OH, 43212

