

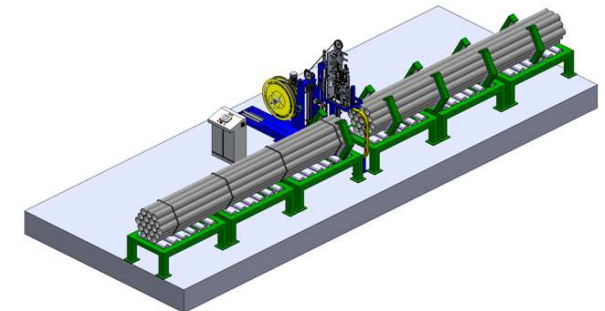

DIFFERENT OPTIONS FOR THE TRANSVERSAL STRAPPING OF ROUND, SQUARE, RECTANGULAR AND HEXAGONAL BUNDLES

INDEX

Description	Page
TRANSVERSAL STRAPPING OF BUNDLES	2
TRANSVERSAL STRAPPING OF BUNDLES	3
TRANSVERSAL STRAPPING OF BUNDLES	4

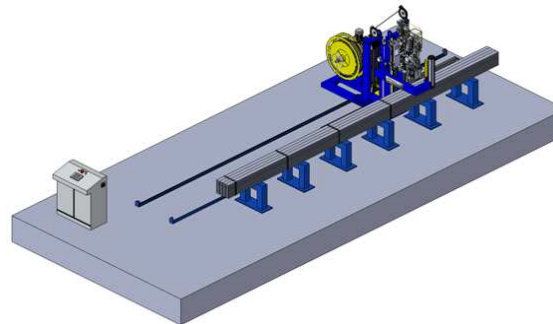
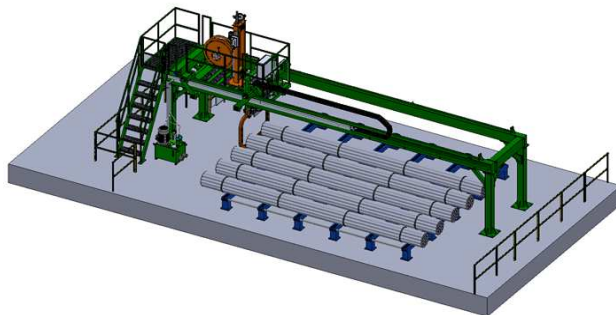

AUTOMATIC STRAPPING MACHINE WITH LATERAL DISPLACEMENT FOR THE TRANSVERSAL STRAPPING OF ROUND BUNDLES

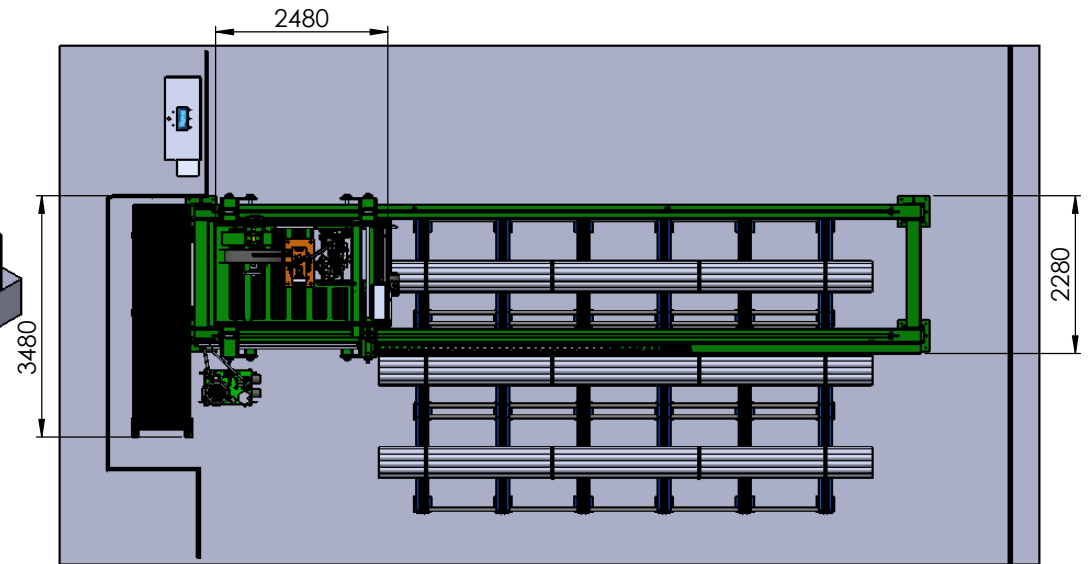
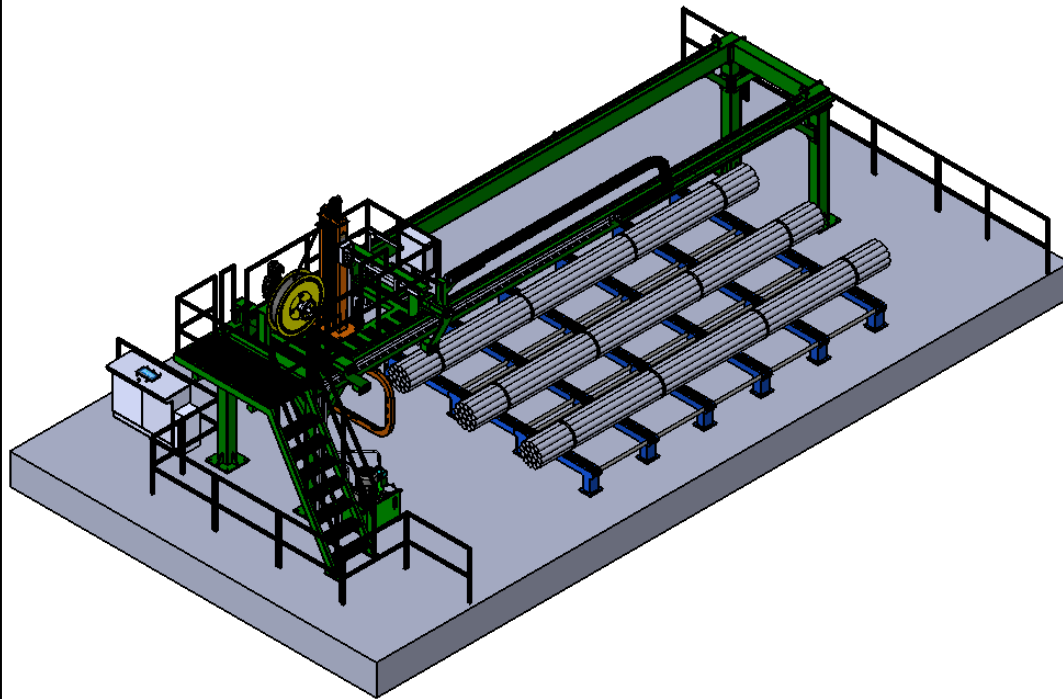
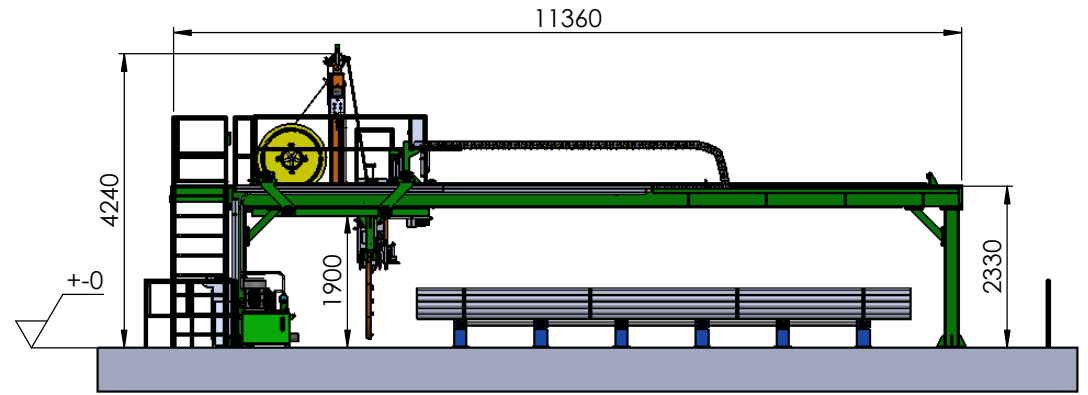
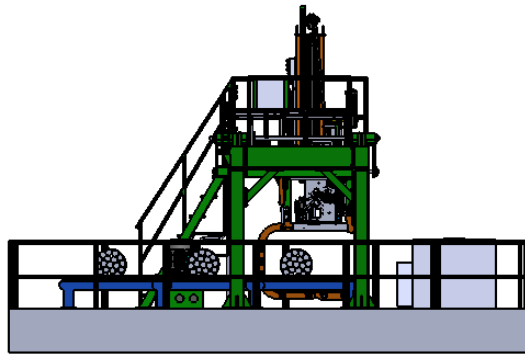

TYPE	KG
STEEL STRAPPING MACHINE	5500
PET STRAPPING MACHINE	5100

AUTOMATIC STRAPPING MACHINE FOR THE TRANSVERSAL STRAPPING OF HEXAGONAL BUNDLES

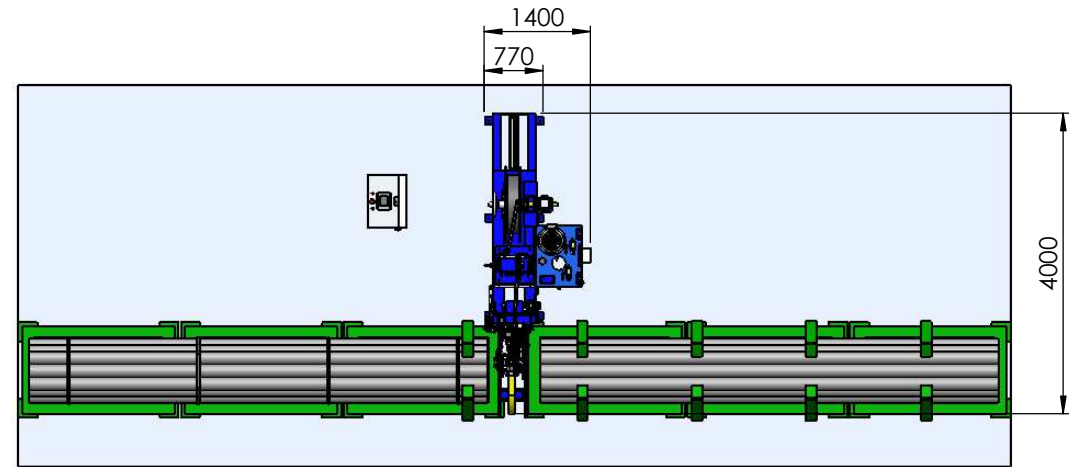
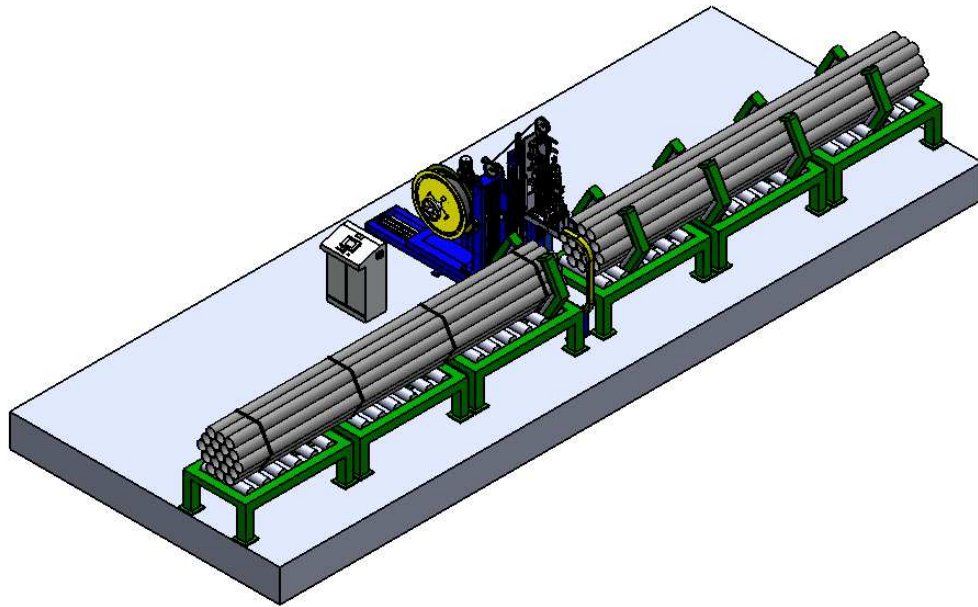
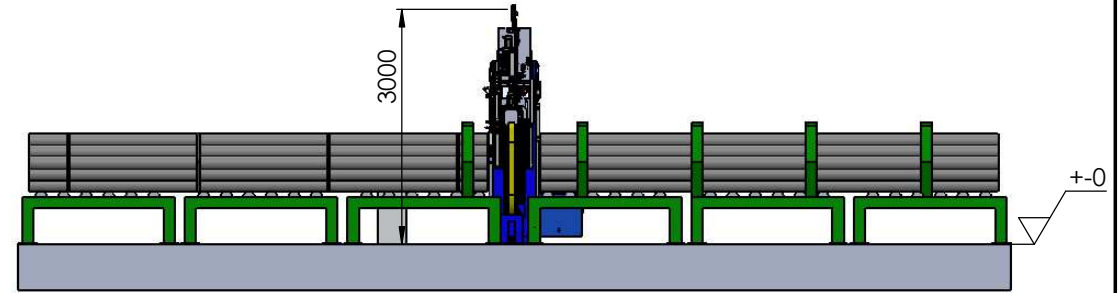
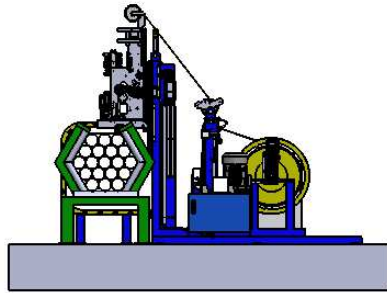

TYPE	KG
STEEL STRAPPING MACHINE	2200
PET STRAPPING MACHINE	1600

AUTOMATIC STRAPPING MACHINE WITH LATERAL MOVEMENT FOR THE TRANSVERSAL STRAPPING OF SQUARE / RECTANGULAR BUNDLES

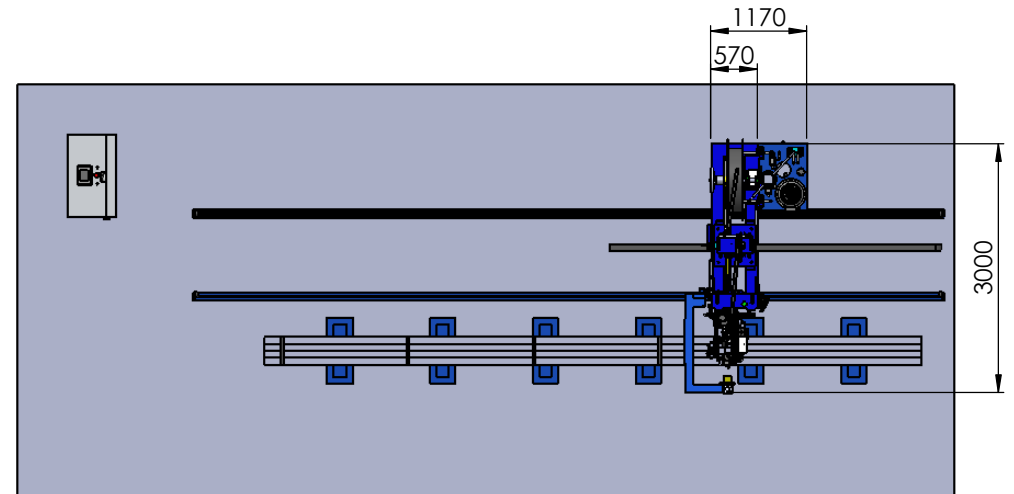
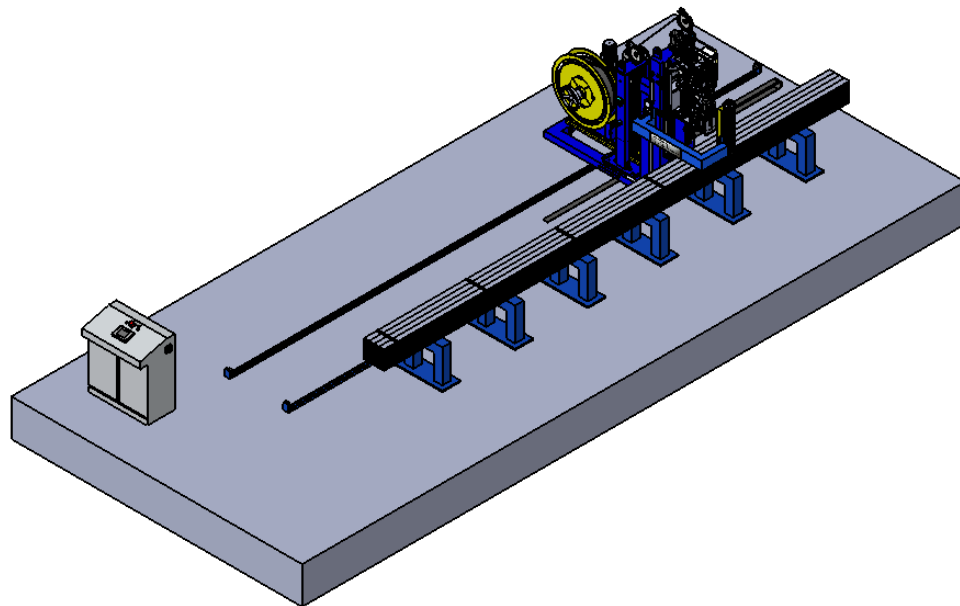
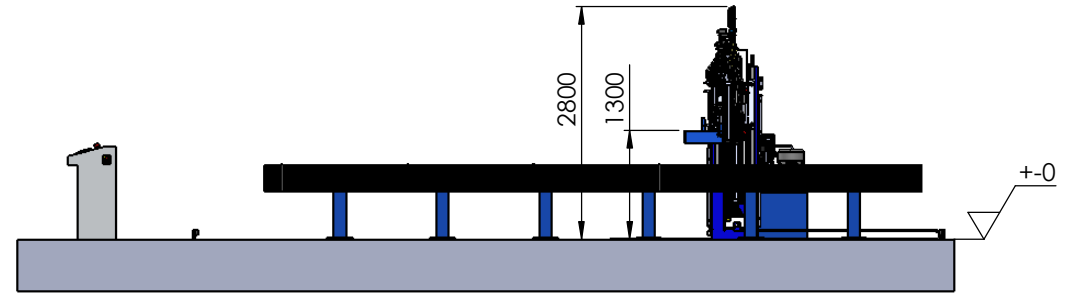
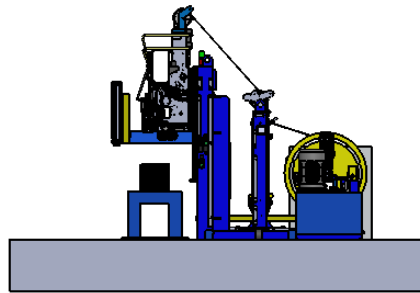

TYPE	KG
STEEL STRAPPING MACHINE	2400
PET STRAPPING MACHINE	2000