

Order from Allstrap 866-779-2673



MAX

265 001100

**Pneumatic strapping
tool for steel strap**

Important!

Do not dispose of this manual. It is the customer's responsibility to ensure that all operators and servicemen read and understand this manual.

Order from Allstrap 866-779-2673

2. General

These operating instructions are meant to facilitate the familiarization with the unit and the intended use. The operating instructions contain important instructions on how the unit can be operated safely, as intended and economically. Following the instructions helps avoid risks, reduce repair works and downtimes and increases the reliability and life of the unit.

These operating instructions must be available at the place where the unit is operated. They must be read and applied by all persons working with the unit. Such works especially include operation, troubleshooting and maintenance.

Apart from the operating instructions and the regulations for the prevention of accidents being applicable in the country where the unit is operated and on site the recognized technical rules for safety-related and competent works have to be observed.

Explanatory notes on the warning and instruction symbols:



Caution!

Is used in case of risks for life and health.



Attention!





Is used in case of risks which might cause damage to objects.



Note!

Is used for general instructions and for remarks whose disregard may cause faults in operations.

This unit is characterized by:

-  Highest performance in relation to tensile force and tensioning speed
-  Robust durable construction
-  Air connection possible „on top“ as well „laterally“
-  No more pneumatic piping, which guarantees absolutely ergonomic design for handling
-  Easy processing of 32 x 0,8 Mega-strap

Copyright © TITAN Umreifungstechnik GmbH & Co.KG 2011 All rights reserved.

The contents of this document must not be duplicated, handed to third parties, published or saved in any form, neither fully nor partly, without prior written permission by TITAN Umreifungstechnik GmbH & Co.KG.



is a registered trademark of TITAN Umreifungstechnik GmbH & Co.KG.

Order from Allstrap 866-779-2673

21. Intended use

- ⓘ This tool is made for strapping of heavy packages such as sectional steel, tubes, coils, etc. The tool is designed and manufactured for safe handling during the strapping operation. This tool is intended for strapping with steel strap material.
- ⓘ The strapping tool complies with the German and European safety standards and is in accordance with.

EU Guidelines:

Guidelines on Machinery 2006/42/EG (Page: 32)

Standards applied and technical specifications:

See declaration of conformity of the machine (Page: 32)

22. Environmental protection notice

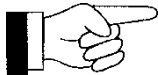

**No hazardous physical or chemical substances are used in the manufacture of the devices.
Comply with the applicable regulations for disposal.**

Order from Allstrap 866-779-2673

3. Technical data

Weight:	11, 3 kg
Incl. suspension:	11, 7 kg
Dimensions	
Without suspension:	L = 410 mm B = 195 mm H = 220 mm
Incl. suspension:	L = 450 mm H = 300 mm
Tension force:	adjustable max. 8000 N
Tensioning speed:	110 mm/sec.
Air pressure:	max. 6.0 bar min. (high-strength quality) 5.0 bar
Air consumption:	11l/sec. tensioning 6NI sealing
Port for air:	G ¼ "
Noise emission:	76 db(A)
Hose:	min. inside diameter = 8 mm
Sealing:	sealing sleeve double notch
Sealing strength:	approx. 75 of the Band load at rupture
Type of sleeve:	RSK 19 = Band width 19mm RSK 25 = Band width 25mm RSK 32 = Band width 32mm

Steel band

Band widths:	19, 25, 32 mm
Standard quality	
Band thickness:	0.8–1,0 mm
Tensile strength:	up to approx. 900 N/mm ²
High-strength quality	
Band thickness:	0.8 mm
Tensile strength:	up to approx. 1100 N/mm ²

Order from Allstrap 866-779-2673

4. Safety Regulations

Intended use

Proper use of this pneumatic tool includes bundling, collecting and securing by means of strapping using steel straps. Packed goods such as section steel, tubes, coils, etc. are suitable application examples.

The device was designed and built for safe operation during strapping.

The device is intended for strapping with steel packaging straps.



Possible misuse!

Strapping material must not be used for the hoisting of loads; this strapping tool may only be used as intended and specified above.

The use of plastic straps is not allowed with this device.

Warranty and liability

TITAN GmbH & Co. KG grants a guarantee of six (6) months for all strapping units sold by it. Such guarantee covers all defects of which evidence can be given that they result from faulty manufacture or material defects.

- ⊘ **Wearing parts are excluded from the guarantee.**

Warranty and liability claims are excluded, if they result from one or several of the following causes:

- ⊘ Unintended use of the unit.
- ⊘ Incompetent mounting, commissioning, operation and maintenance of the unit.
- ⊘ Operating the unit with improper safety and protective installations.
- ⊘ Disregard of the instructions in these operating instructions.
- ⊘ Unauthorized structural alterations to the unit.
- ⊘ Faulty monitoring of unit components subjected to wear.
- ⊘ Incompetently performed repair works.

Alterations to the scope of supply with the aim to improve the product without notice.

Order from Allstrap 866-779-2673

Failure to comply with the following safety instructions, in addition to errors in handling the device, can result in serious injuries.



Be informed!

Read the operating manual carefully before using the device



Protect yourself!

Always wear eye, face and hand protection (cut-resistant gloves) when working.



Attention!

Strap flies outward!

When cutting the strap, hold the top part firmly and stand to the side.

Attention! The lower part of the strap will fly outward.



Attention!

Strap can break!

The strap can break during tightening! Do not stand in the path of the strap. Make sure that no one else is in the working area.

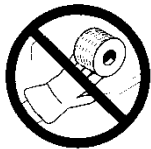

Caution!

Danger of crushing!

Do not insert fingers into the pulley area.



Caution!

Strap only objects to be packed!

Make sure that no hands or other body parts are between the strap and the goods to be packaged.



Use only original TITAN replacement parts!

The use of parts other than original **TITAN** replacement parts will void the warranty and all liability.



Use only lifting gear that complies with the safety regulations!

Order from Allstrap 866-779-2673



Only use original **TITAN locking sleeves!**



Do not exceed air pressure!

Do not exceed the max. air pressure of 6.0 bar required.



Use original reception couplings.

Only reception couplings meeting safety requirements may be used.



Do not use gas or compressed air bottles! The unit must not be connected to a gas or compressed air bottle.



The use of band which is not recommended may result in tears during the tensioning and bad sealing qualities. Only use the relevant **TITAN quality products!**



This unit may only be operated by staff having been instructed as to the handling of the unit. In case of questions do not hesitate to contact the **TITAN packing consultant.**

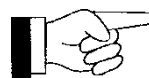

Working place

Keep your working place tidy. Disorder at the working place may lead to the risk of accidents. During strapping operations pay attention that you stand safely and have a problem-free balance to prevent the risk of falling. Never operate the unit at an unfavourable working position!



Maintenance of the unit

Just a unit being problem-free is a safe unit. Regularly check the state of your unit for defective or worn parts. Never operate a unit which has defective or worn parts. Alterations to units are strictly forbidden. Disregarding this requirement may result in serious injuries.

Order from Allstrap 866-779-2673

5. Initial operation

5.1. Suspension of the unit

The unit is provided with a swinging suspension shackle on which it can be suspended in the three important working positions (anti-g) by means of a balancer).

Normal position

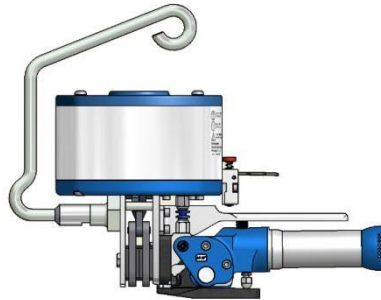

Vertical position

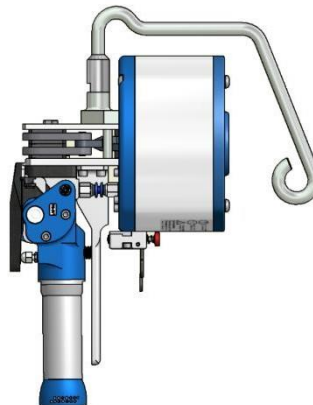

Horizontal position

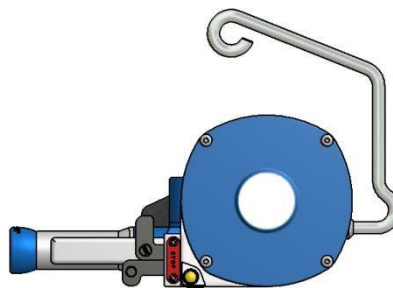

Order from Allstrap 866-779-2673

5.2 Compressed air preparation and port

Motor and compressed air cylinder are lubricated by the oil vapour of the compressed air. Faultlessly prepared compressed air is therefore a prerequisite for a problem-free operation of the unit. This can only be met by a properly working 3/8" maintenance unit comprising water separator, pressure reducing valve incl. pressure gauge and oiler.

The oiler is to discharge sufficient oil, i.e. approx. 1 drop per strapping operation. The length of the hose should not exceed 5 m. The inside diameter of the hose is minimum 8 mm. Attention should be paid, that the hose is without loops in which oil could gather. Choice of the lubricating oil: resin- and acid-free lubricating oil with a viscosity of 2-4° E at 50°.



In no case it is allowed to run the tool without oil being in the lubricator of the maintenance unit, as this would immediately destroy the compressed air motor. No warranty in that case.

Max. operating pressure 6 bar.

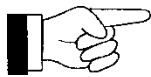

Attention!

Risk of tearing band!

The band can get torn when the operating pressure of 6 bar is exceeded. Tearing band can result in injuries of the operating staff.

6. Operating Instructions

6.1. Structure

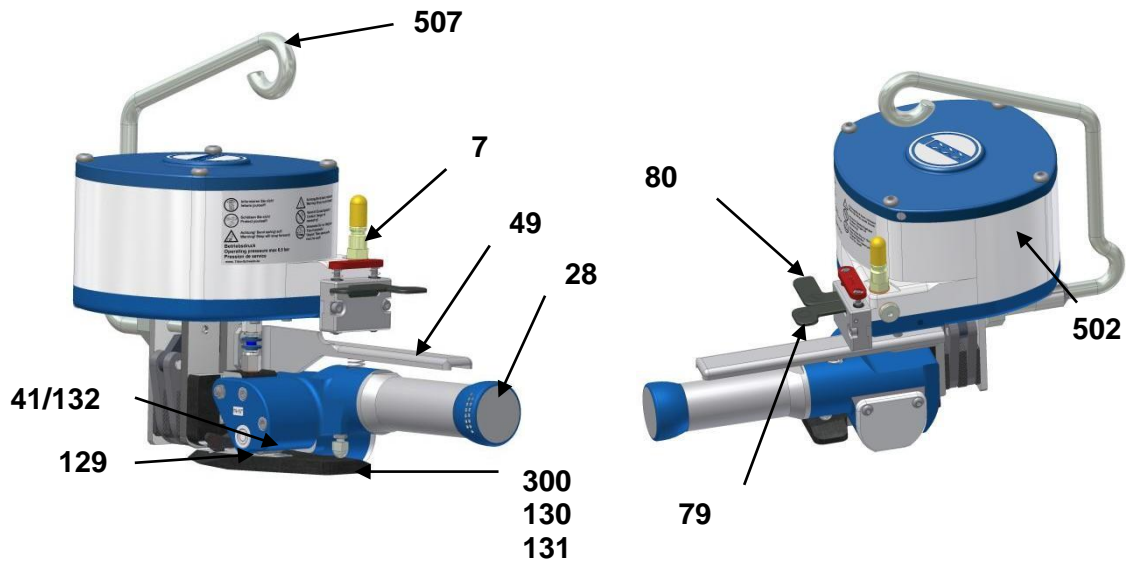

- 7 Compressed air port nipple
- 130 Tension element
- 131 Tension element
- 300 Lifting lever
- 49 Lifting lever
- 507 Suspension

- 79 Tension lever
- 80 Locking lever
- 129 Guide plate
- 41/132 Transport wheel
- 28 Compressed air motor
- 502 Cylinder

6.2. Functional principle

1. Manually lead band through the sleeve,
2. Bend beginning of band,
3. Tension by means of transport wheel,
4. Lock by notching the sleeve,
5. Cutting the band fed

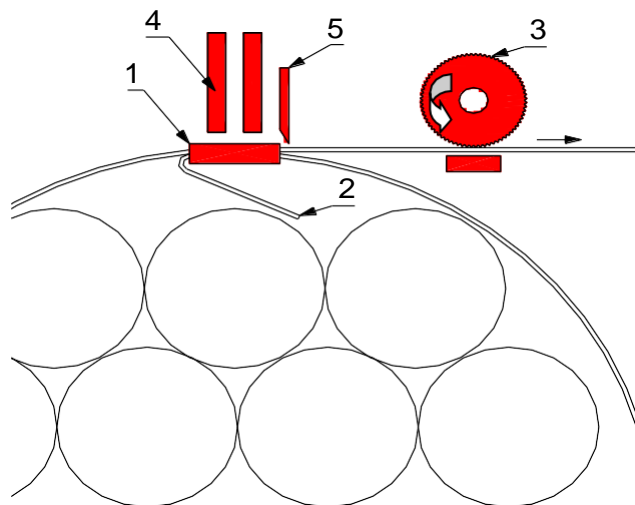

Order from Allstrap 866-779-2673

6.3. Operating the unit

Strapping the steel band

The steel band is routed from the uncoiler through the locking sleeve around the packing item and again through the sleeve.



Bending the beginning of band

The beginning of band is routed through the locking sleeve, approx. 4-5 cm, then it is bent sharply below the sleeve.

The loop resulting that way is pulled tight manually. The bent beginning of band must in any case be in contact with the packing item to be strapped.



Apply the unit

Hold the steel band being on top with your left hand. Press lifting lever and compressed air motor with your right hand. Slip the band below the tension wheel and then forward to the locking sleeve. Lower compressed air motor.



Order from Allstrap 866-779-2673

Tensioning

Press the right switch-on key with the thumb of your right hand. The key is caught, until the tensioning is finished. The staff can interrupt the tensioning by pressing the red key on the right side.



Sealing

Use the thumb of your right hand to press the left switch-on key until the sleeve is closed and the band is cut. The unit then releases the seal. Hold the end of band cut with your left hand and press the lifting lever and the compressed air motor.

To be sure that the unit formed a clean seal, check the strapping thoroughly.



The following picture shows a correctly carved seal.

Check the seals regular:

- ⊘ for crackings on the sleeve and
- ⊘ for neat cutting edges.

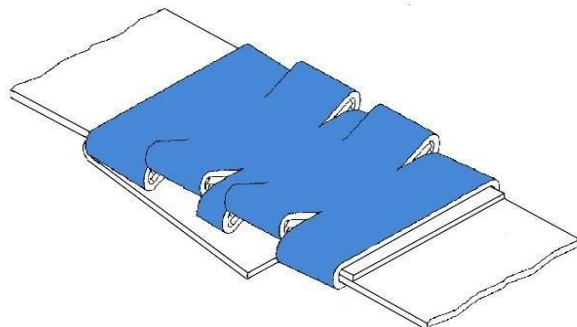

7. Operating Instructions

7.1. Distance between transport wheel and guide plate

The distance between transport wheel **41/132** and guide plate **129** is max. **0.2 mm**. The transport wheel and the guide plate may not come into contact with each other.

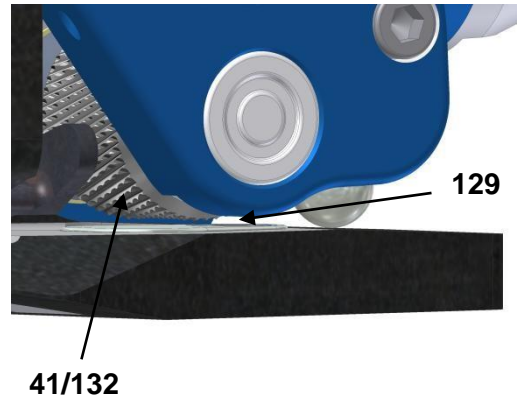

Setting:

Loosening the counternut **164** by means of a 10 wrench. Use a 12 wrench to set gap dimension with the adjusting screw **116**. Screw counternut.

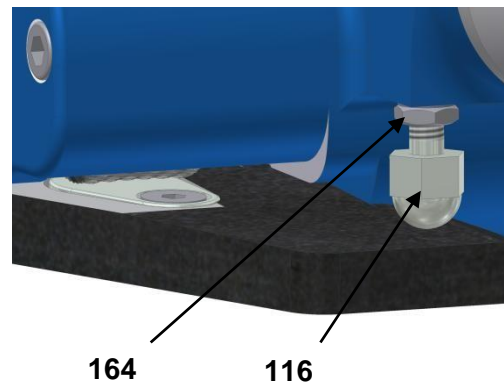

7.2. Setting the band tension

Setting the maintenance unit to 4 to 6 bar.

Loosen counternut **98** by means of a 8 wrench. Setting the band tension by means of hexagon socket screw key 2,5 mm. CW lower band tension, ccw higher band tension.

After the setting tighten counternut **98**.

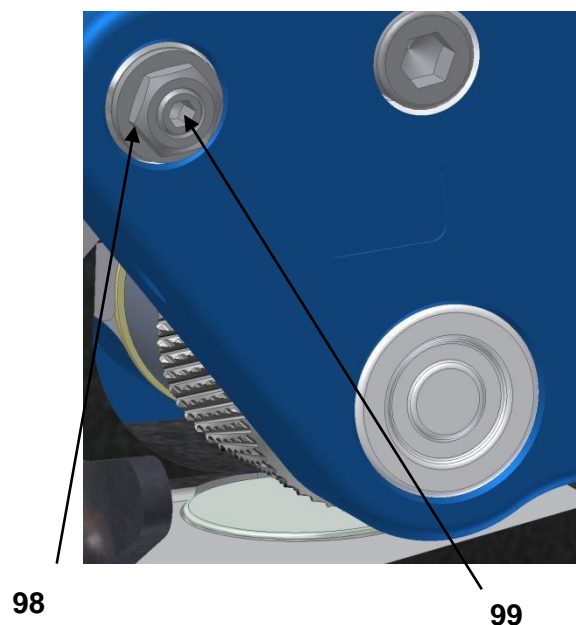

Order from Allstrap 866-779-2673

8. Maintenance

8.1. Cleaning and maintenance of the unit

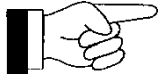

Dirt and abrasion impair the function of the unit. Therefore, clean the following areas every week.
If possible, perform air-cleaning (wear protective glasses).

- ④ Insertion slot.
- ④ Hollow spaces of the sealing pincers.
- ④ Transport wheel.
- ④ Guide screw

Then oil it with a commercial spray oil.

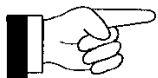

Do not use any solvent containing cleaning agents for reasons of health.

Maintenance unit!

- ④ daily check of the compressed air
- ④ daily check of the oil level
- ④ draining the water separator
- ④ cleaning the filter according to instructions

Tool inspection!

Perform a daily visual inspection of the outside of the unit. The early detection of damaged parts extends the life of the unit. Replace all damaged parts with new parts.

Order from Allstrap 866-779-2673

9. Declaration of conformity of the machinery

EC declaration of conformity of the machinery

in terms of the directive 2006/42/EC on machinery, Annex II A

The manufacturer

TITAN Umreifungstechnik GmbH & Co.KG
Berliner Straße 51-55
58332 Schwelm

herewith declares that the pneumatic strapping tool for steel strap described below

Type designation: MAX
Serial number: 265 001100

corresponds to the provisions of the following EC directive:

Machine directions 2006/42/EG

Used harmonised standards, published in the official journal of the EU:

EN ISO 12100-1: 2004, Safety of machinery – Basic concepts, general principles for design - Part 1: Basic terminology, methodology

EN ISO 12100-2: 2004, Safety of machinery – Basic concepts, general principles for design - Part 2: Technical principles and specifications

EN 1010-1:2005 Safety of machinery – Safety requirements for the design and construction of printing and paper processing machines - Part 1: General requirements (Final concept 02/2003)

EN 1010-3: 2002, Safety of machinery - Safety requirements for the design and construction of printing and paper processing machines - Part 3: Cutting machines

A non-approved modification of the machinery implicates the loss of validity of this declaration.

Authorized representative for the compilation of the technical documentation:

TITAN Umreifungstechnik GmbH & Co. KG
Berliner Strasse 51-55
58332 Schwelm

Schwelm, the 26.03.2012

Peter Wilhelm Lenzen
President

TITAN Umreifungstechnik GmbH & Co. KG Sitz der Gesellschaft: Schwelm HR A 4724, Amtsgericht Hagen USt-Ident.Nr. DE 187983242	Persönlich haftende Gesellschafterin TITAN Umreifungstechnik Verwaltungsgesellschaft mbH Sitz der Gesellschaft: Schwelm HR B 6416, Amtsgericht Hagen Geschäftsführer: Peter Wilhelm Lenzen	Commerzbank AG, Iserlohn Volksbank Hohenlimburg eG Postbank Dortmund Kreissparkasse Düsseldorf	BLZ 445 400 22 BLZ 450 615 24 BLZ 440 100 46 BLZ 301 502 00	Kto. 571 250 700 Kto. 4 046 373 900 Kto. 004 843 04 63 Kto. 2 057 453	BIC: COBA DE FF 445 BIC: GENO DE M1 HHH BIC: PBNK DEFF 440 BIC: WELA DE D1 KSD	IBAN: DE41 4454 0022 0571 2567 00 IBAN: DE32 4506 1524 4046 3739 00 IBAN: DE52 4401 0046 0048 4304 63 IBAN: DE40 3015 0200 0002 0574 53
---	---	---	--	--	---	--

Distributed By:

Allstrap

1719 Kenny Rd
Columbus, OH, 43212